

WCN1-0050B7-A11**SPECIFICATION**

WCN			CUSTOMER Confirmed
Prepared by	Checked by	Approved by	
Fei	Athena		
REVISION RECORD			

**REVISION: A0**

Outer Dimension:

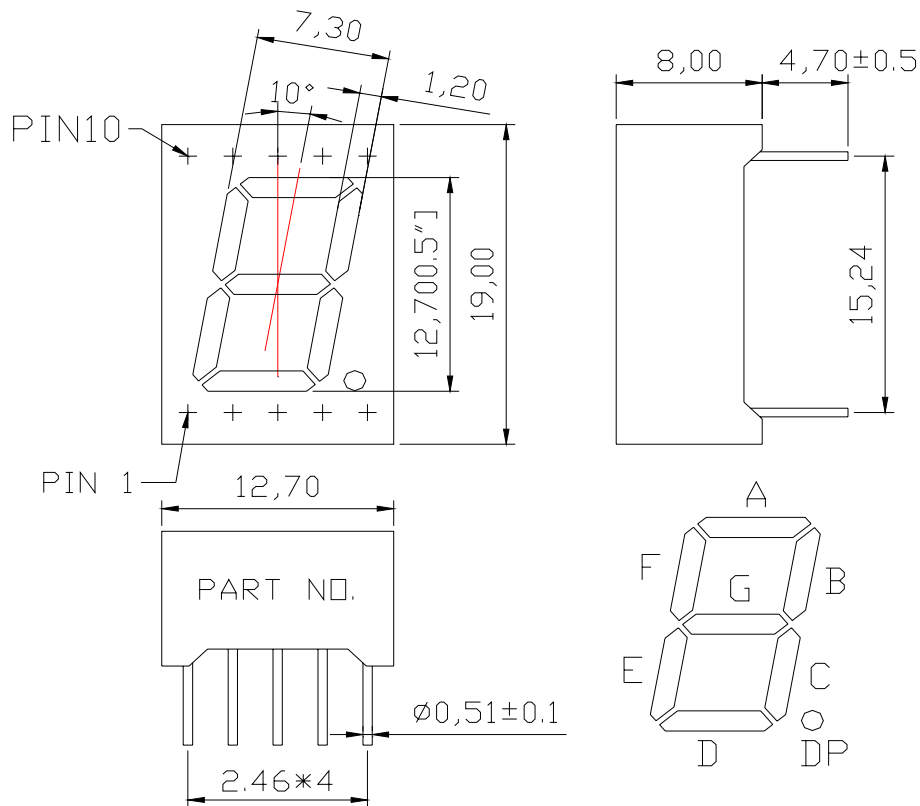

Notes: Unless otherwise stated, the tolerance is 0.25mm.

Circuit Diagram

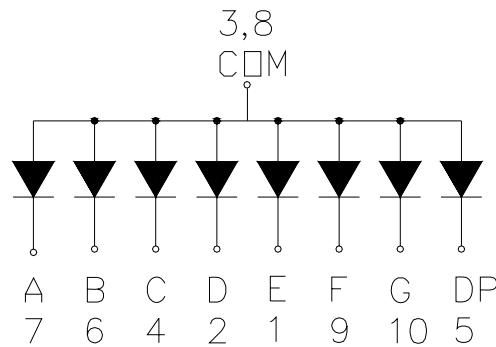

Pin Connection:

PIN NO.	CONNECTION	PIN NO.	CONNECTION
1	Cathode E	6	Cathode B
2	Cathode D	7	Cathode A
3	Common Anode	8	Common Anode
4	Cathode C	9	Cathode F
5	Cathode DP	10	Cathode G

WCN Opto Group Co., Limited

Features:

- . High Reliability
- . Color: Blue
- . Low Power Requirement
- . Easy Assembly

Description:

- . Single Digit LED Display
- . Digit Height: 12.7mm(0.50")
- . Black Face and Milky Segment

Absolute Maximum Rating (Ta=25):

Parameter	Symbol	Condition	Color	Rating	Units
Power Dissipation Per Segment	P _d		Blue	90	mW
Forward Current Per Segment	I _F		Blue	25	mA
Peak Forward Current Per Segment	I _{FP}	1/10 Duty 10KHz	Blue	100	mA
Reverse Voltage Per Segment	V _R		Blue	5	V
Operating Temperature Range	T _{opr}			-35 +85	
Storage Temperature Range	T _{stg}			-35 +85	

Electrical/Optical Characteristics Rating(Ta=25)

Item	Symbol	Test conditions	Location	Rating			Units
				Min.	Typ.	Max.	
Forward Voltage	V _F	I _F =20mA	Per Segment		3.20	3.60	V
Reverse Current	I _R	V _R =5V	Per Segment			100	A
Luminous Intensity	I _V	I _F =10mA	Per Segment	10501	16600		cd
Peak Emission Wave Length	P	I _F =20mA	Per Segment				nm
	D			465	470	475	
Spectral Line Half Width		I _F =20mA	Per Segment		30		nm
Luminous Intensity Matching Ratio (Segment to Segment)	I _{v-m}	I _F =10mA				1.2:1	

Luminous Intensity Sorting: (Luminous Intensity Tolerance is +/-10%)

Rank	Symbol	Condition	Min	Max	Unit
Q	Q	I _F =10mA	10501	12800	cd
R	R	I _F =10mA	12801	15250	cd
S	S	I _F =10mA	15251	18000	cd
T	T	I _F =10mA	18001	21500	cd
U	U	I _F =10mA	21501	26000	cd

**Soldering Conditions: Soldering Temp. +260 , Soldering Time. 3sec.
(at 2mm Distance from The Case of Reflector Edge)**

Typical Electro-Optical Characteristics Curve:

Fig1. Forward Current vs. Forward Voltage:

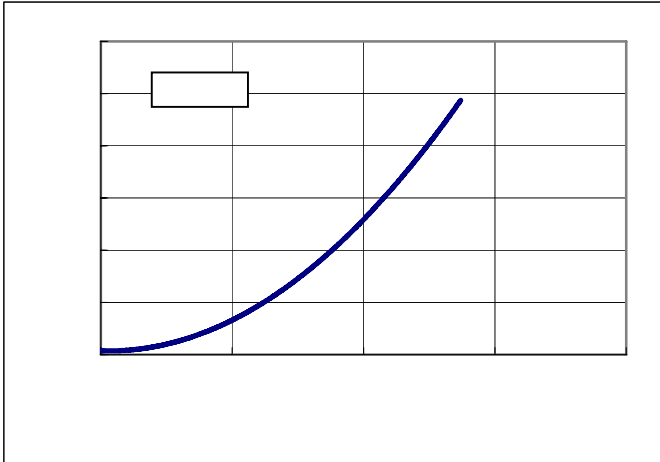

Fig2. Forward Current vs. Relative Intensity:

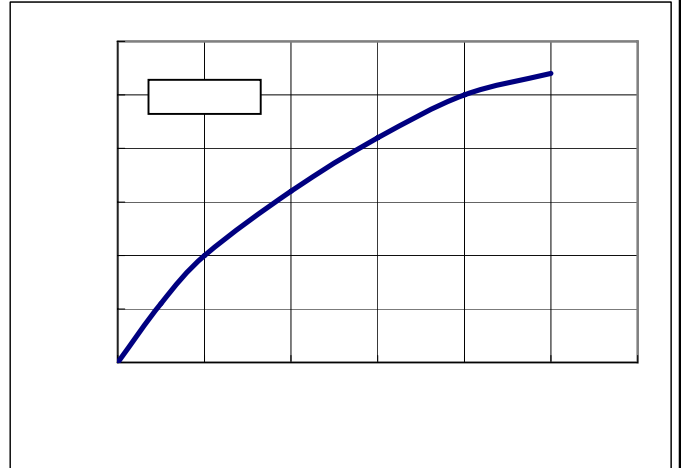
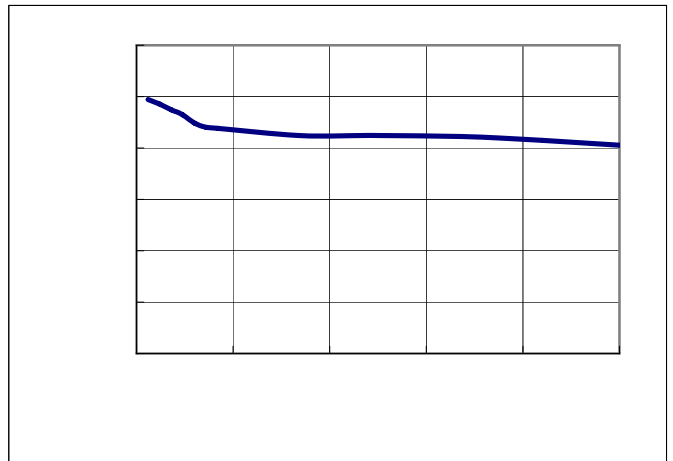

Fig3. Forward Current vs. Relative wavelength:



Fig4. Life Test at 20mA R.T. 1000hrs:



WCN Opto Group Co., Limited

LED Displays Reliability Test:

CLASSIFICATION	TEST ITEM	DESCRIPTION AND TEST CONDITION
ENDURANCE TEST	OPERATION LIFE	EVALUATES RESISTANCE OF THE DEVICE WHEN OPERATED AT ELECTRICAL STRESS T _a = UNDER ROOM TEMPERATURE I _F = I _F max
	HIGH TEMPERATURE HIGH HUMIDITY STORAGE	EVALUATES MOISTURE RESISTANCE OF THE DEVICE WHEN STORED FOR A LONG TERM AT HIGH TEMPERATURE AND HUMIDITY T _a = 65±5°C RH=90~95%RH TEST TIME=240± 2Hrs
	HIGH TEMPERATURE STORAGE	EVALUATES DEVICE DURABILITY FOR LONG TERM STORAGE IN HIGH TEMPERATURE T _a = 85±5°C(COB: T _a =65±5°C) TEST TIME=1000Hrs(-24Hrs, +72Hrs)
	LOW TEMPERATURE STORAGE	EVALUATES DEVICE DURABILITY FOR LONG TERM STORAGE IN LOW TEMPERATURE T _a = -35±5°C TEST TIME=1000Hrs(-24Hrs, +72Hrs)
ENVIRONMENTAL TEST	TEMPERATURE CYCLING	EVALUATES RESISTANCE OF DEVICE AT THERMAL STRESSES OR EXPANSION AND CONTRACTION 85°C ~ 25°C ~ -35°C ~ 25°C 30min 5min 30min 5min 10 CYCLES(COB: T _{hot} =65°C, T _{cold} =-25°C)
	THERMAL SHOCK	EVALUATES DEVICE STRUCTURE AND STRUCTURE AND MECHANICAL RESISTANCE WHEN SUDDENLY EXPOSED AT SERVE CHANGES 85±5°C ~ -35±5°C 10min 10min 10 CYCLES(COB: T _{hot} =65°C, T _{cold} =-25°C)
	SOLDERABILITY	EVALUATES SOLDERABILITY ON LEADS OF DEVICE T.SOL=230±5°C DWELL TIME=5±1sec.
	SOLDER RESISTANCE	EVALUATES RESISTANCE TO THERMAL STRESS CAUSED BY SOLDERING T.SOL=260±5°C DWELL TIME=10±1sec.

Package Pattern 1:

175pcs / Red Expandable Polyethylene.

1050pcs / Box(360*175*130mm).

6300pcs / Carton(550*380*280mm).

Package Pattern 2:

40pcs / IC Tube.

1680pcs / Box(537*175*125mm).

6720pcs / Carton(550*380*280mm).