

**World Components Network Service Ltd****Customer Name:****Date:**

2016-2-23

**Part No:**

WCN2S-1040SR-A1

**Product Group  
Description:**

LED Display

**Customer Part No:****Approval Date:****Customer  
Confirmation****Approved by****Checked by**Athena  
2016-2-23**Prepared By**Fei  
2016-2-23

Country of Origin: China

**World Components Network Service Ltd**5th Floor,Block A-2,Xuxingda Ind Zone  
Shiyan Town,Bao An District , Shenzhen  
Tel : (86)755-2900022  
Fax : (86)755-2900023[www . wcnopto.net](http://www.wcnopto.net)

**Table of Contents**

<b>NO.</b>	<b>ITEM</b>	<b>PAGE</b>
1	Cover	1
2	Table of Contents	2
3	Revision Record	3
4	Description	4
5	Outer Dimension and Circuit Diagram	5
6	Absolute Maximum Rating and Electrical/Optical Characteristics Rating	6
7	Typical Electrical/ Optical Characteristic Curves and Spectrometer	7
8	Packaging Data	8
9	Moisture Proof Packaging	9

# World Components Network Service Ltd

## REVISION RECORD

MARKER	Matter for revision	SHEET	DTAE	MAKER	APPOVED SIGN	
	Reason for revision					
A0	P# WCN2S-1040SR-A1	Whole Spec	2013-8-27	LIU	Athena	
	New Version issued					
A1	Add Package Data	Page.5	2015-3-13	LIU	Athena	
	Improved					
A2	Add Package Data	Page.5	2015-5-11	LIU	Athena	
	Improved					
A3	Change File's Set Type	Whole Spec	2016-2-23	Fei	Athena	
	Improved					

**1. Type No./Manufacture's Name**

WCN2S-1040SR-A1 / World Components Network Service Ltd.

**2. Features:**

- High Reliability
- Low Power Requirement
- Easy Assembly

**3. Faction: Display Digit Characteristic****4. Soldering Conditions: Soldering Temp.  $260 \pm 5$  °C, Soldering Time. 3~5 sec.**

Soldering Power <30 W.

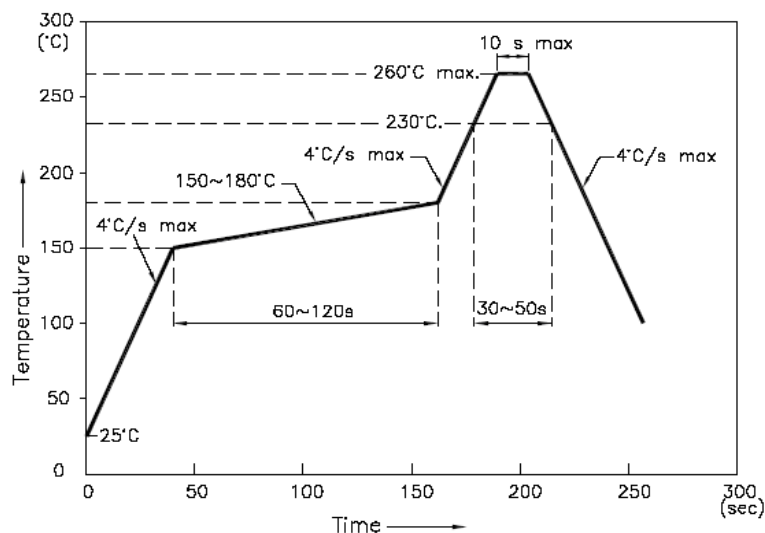
**5. Re-flow Temp/Time****NOTES:**

5.1. We recommend the re-flow temperature  $245^{\circ}\text{C} (\pm 5^{\circ}\text{C})$ . the maximum soldering temperature should be limited to  $260^{\circ}\text{C}$ .

5.2. Don't cause stress to the epoxy resin while it is exposed to high temperature. Number of re-flow process shall be 2 times or less.

**6. Description:**

- Two Digit LED Display
- Digit Height: 10.16mm (0.40" )
- Gray Face and Milky Segment
- Color: Red

### Outer Dimension:

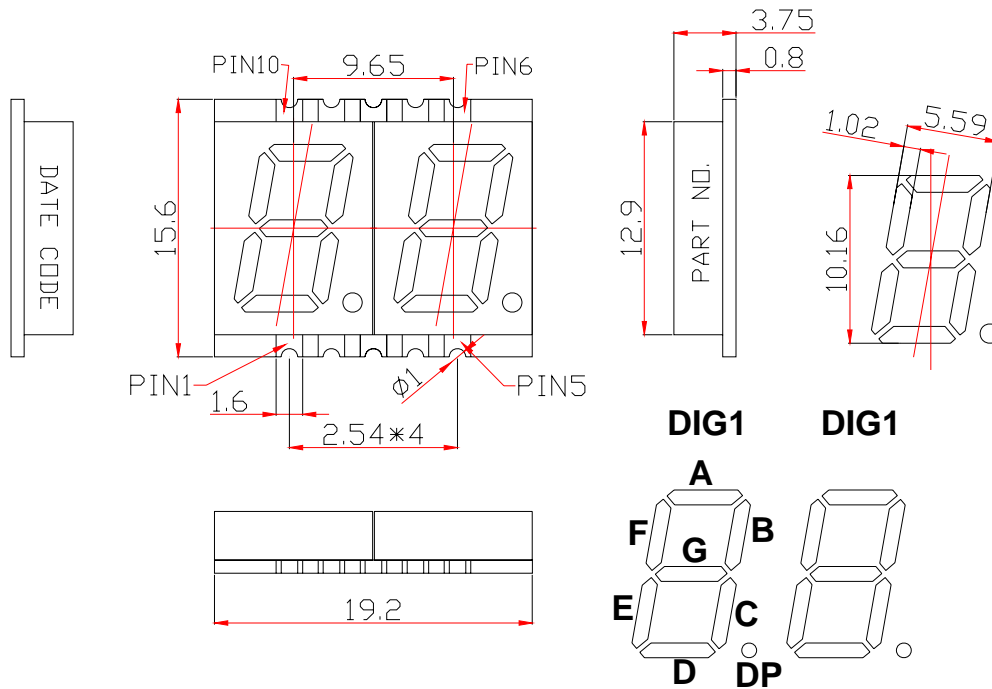

Notes: Unless otherwise stated, the tolerance is  $\pm 0.25\text{mm}$ .

### Circuit Diagram:

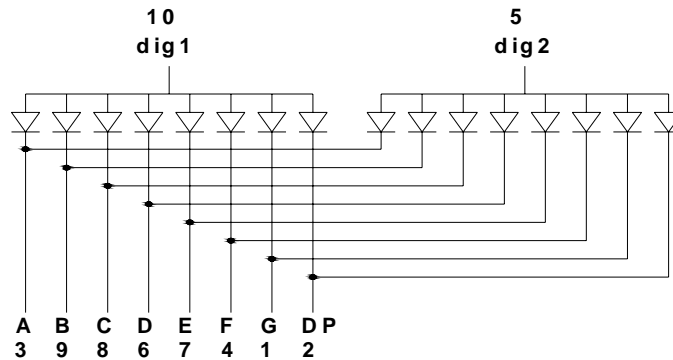

### Pin Connection:

PIN NO.	CONNECTION	PIN NO.	CONNECTION
1	Cathode G	6	Cathode D
2	Cathode DP	7	Cathode E
3	Cathode A	8	Cathode C
4	Cathode F	9	Cathode B
5	Common Anode dig2	10	Common Anode dig1

# World Components Network Service Ltd

## ■ ABSOLUTE MAXIMUM RATINGS AT TA=25°C

Parameter	Symbol	Condition	Color	Rating	Units
Power Dissipation Per Segment	$P_d$	—	Red	62.5	mW
Forward Current Per Segment	$I_F$	—	Red	25	mA
Peak Forward Current Per Segment	$I_{FP}$	1/10 Duty 1KHz	Red	100	mA
Reverse Voltage Per Segment	$V_R$	—	Red	5	V
Operating Temperature Range	$T_{opr}$	—	—	-40~+105	°C
Storage Temperature Range	$T_{stg}$	—	—	-40~+105	°C

## ■ Electrical/Optical Characteristics Rating(Ta=25°C)

Item	Symbol	Test conditions	Location	Rating			Units
				Min.	Typ.	Max.	
Forward Voltage	$V_F$	$I_F=20mA$	Per Chip	1.80	2.00	2.50	V
Reverse Current	$I_R$	$V_R=5V$	Per Chip	—	—	100	$\mu A$
Luminous Intensity	$I_V$	$I_F=10mA$	Per Chip	2001	4500	—	ucd
Wave Length	$\lambda_P$	$I_F=20mA$	Per Chip	—	640	—	nm
	$\lambda_D$			627	630	633	
Spectral Line Half Width	$\Delta \lambda$	$I_F=20mA$	Per Chip	—	—	20	nm
Luminous Intensity Matching Ratio (Segment To Segment)	$I_{v-m}$	$I_F=10mA$				1.2:1	

## ■ Luminous Intensity Sorting: (Luminous intensity tolerance :+/-10%)

Rank	Symbol	Condition	Min	Max	Unit
I	I	$I_F=10mA$	2001	3200	$\mu cd$
J	J	$I_F=10mA$	3201	5050	$\mu cd$
K	K	$I_F=10mA$	5051	8000	$\mu cd$

■ **Typical Optical-Electronic Characteristic Curves**

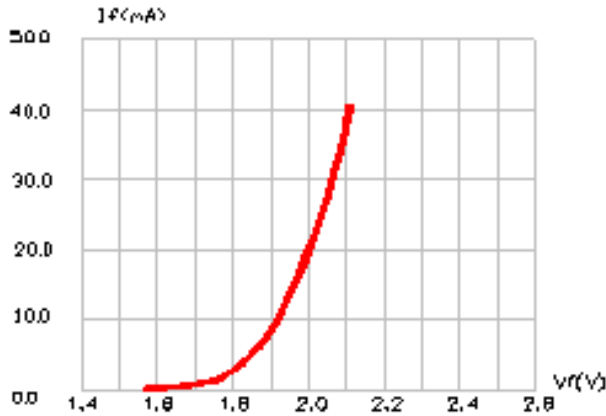

FIG.1 FORWARD CURRENT VS. FORWARD VOLTAGE

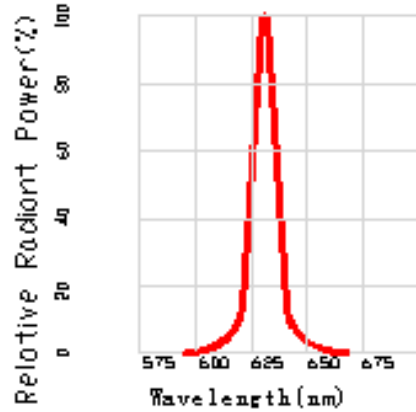

Fig.2 Relative Radiant Power vs. Wavelength

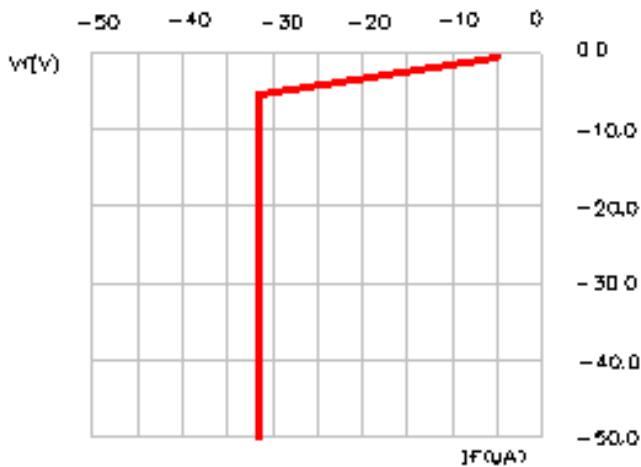

FIG.3 REVERSE CURRENT VS. REVERSE VOLTAGE.

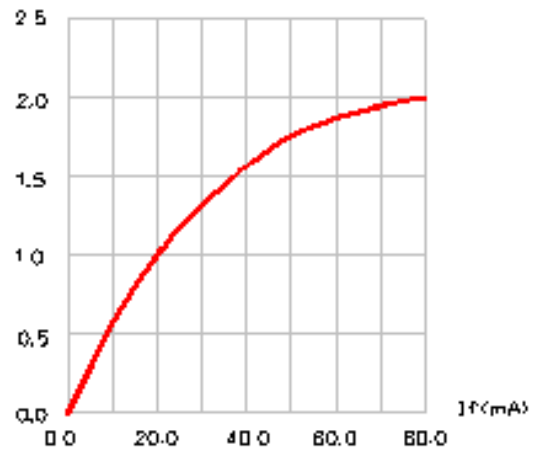

FIG.4 RELATIVE LUMINOUS INTENSITY VS. FORWARD CURRENT.

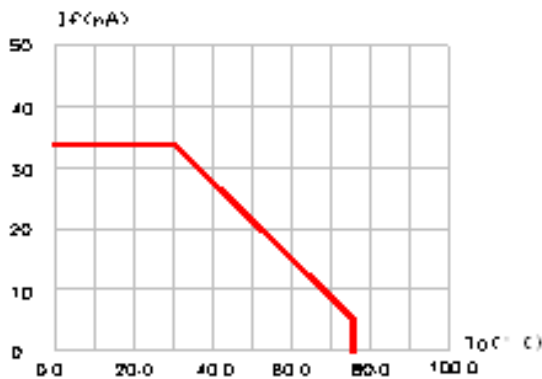
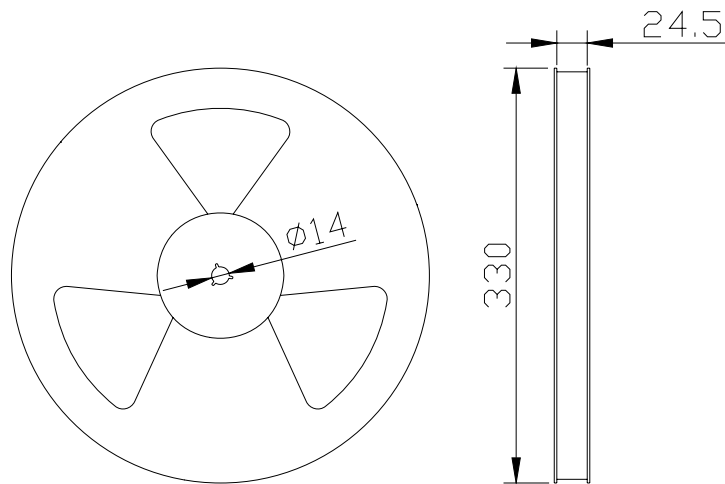
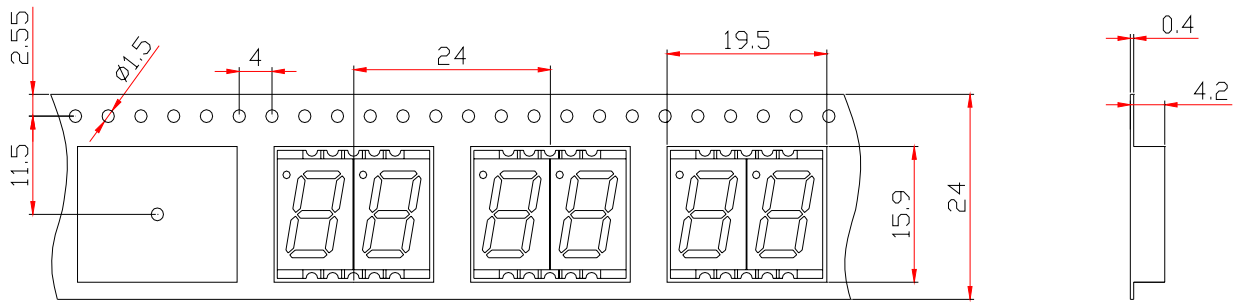

FIG.5 MAXIMUM FORWARD DC CURRENT VS AMBIENT TEMPERATURE ( $T_{max}=95^{\circ}$  C)

■ Packing Reel Dimensions(mm):



■ Dimensions of Tape (Unit: mm)



■ One Reel contained 600 PCS products:

■ Recommended Soldering Pattern:

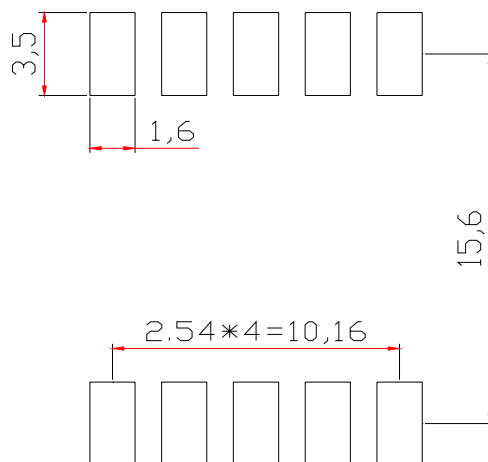



■ **Moisture Proof Packaging:**

All N/D SMD displays are shipped in moisture proof package. The displays should be stored at 30°C or less and 60% RH or less. Once the package opened, moisture absorption begins.

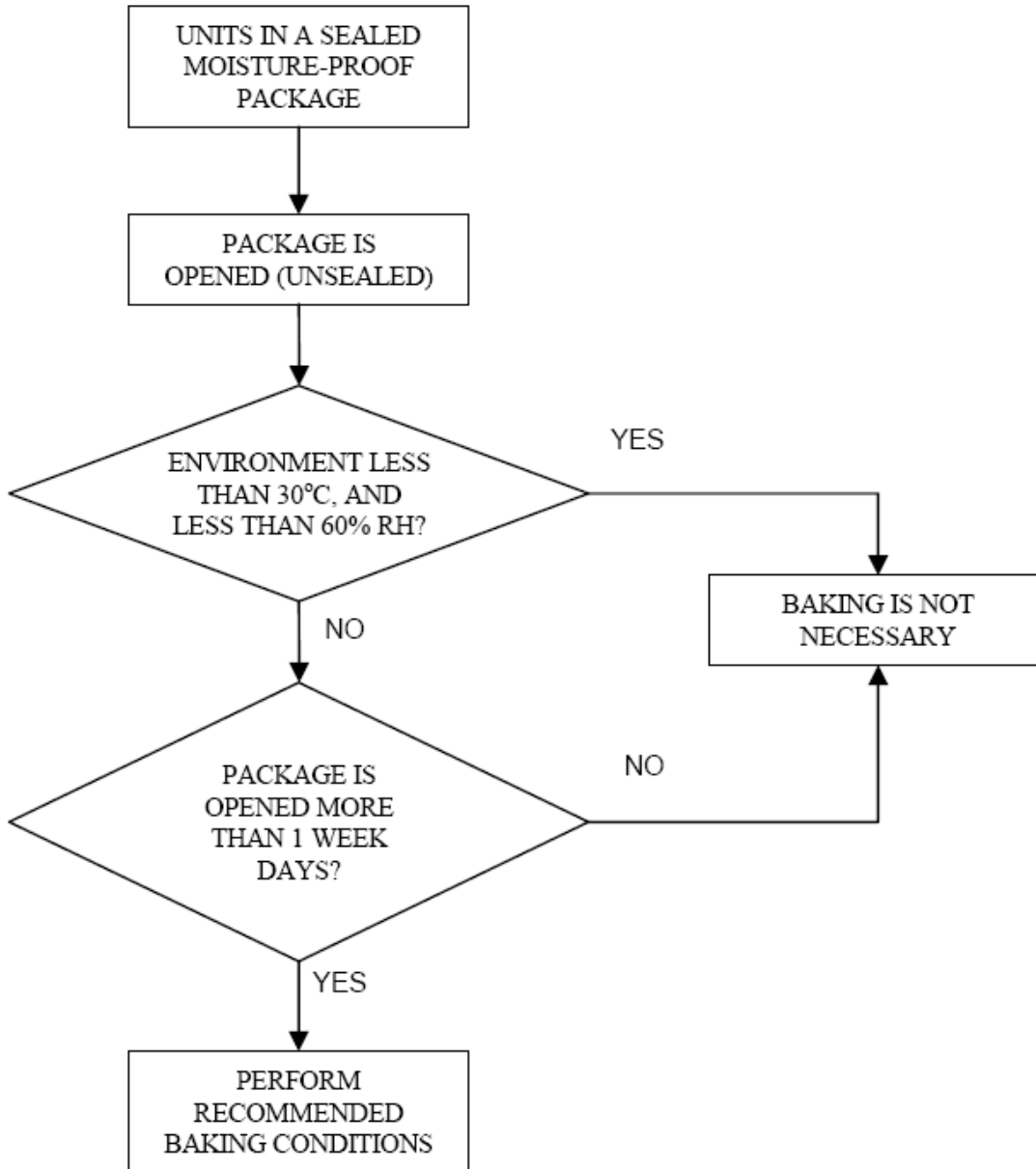

■ **Baking Conditions:**

If the parts not stored in dry conditions, they must be baked before re-flow to prevent damage to the parts.

Package	Temperature	Time
In Reel	60 °C	≥ 48hours
In Bulk	100 °C	≥ 4hours
	125 °C	≥ 2hours

■ **Baking should only be done once.**