

World Components Network Service Ltd**Customer Name:****Date:****2016-7-21****Part No:****WCN3S-1039SR-C1****Product Group
Description:****LED Display****Customer Part No:****Approval Date:****Customer
Confirmation****Approved by****Checked by****Athena
2016-7-21****Prepared By****Fei
2016-7-21****Country of Origin: China****World Components Network Service Ltd****5th Floor,Block A-2,Xuxingda Ind Zone
Shiyan Town,Bao An District , Shenzhen
Tel : (86)755-29000022
Fax : (86)755-29000023****www . wcnopto.net**

Table of Contents

NO.	ITEM	PAGE
1	Cover	1
2	Table of Contents	2
3	Revision Record	3
4	Description	4
5	Outer Dimension and Circuit Diagram	5
6	Absolute Maximum Rating and Electrical/Optical Characteristics Rating	6
7	Typical Electrical/ Optical Characteristic Curves and Spectrometer	7
8	Packaging Data	8
9	Moisture Proof Packaging	9

World Components Network Service Ltd

REVISION RECORD

MARKER	Matter for revision	SHEET	DTAE	MAKER	APPOVED SIGN	
	Reason for revision					
A1	<p style="margin: 0;">P# WCN3S-1039SR-C1</p> <hr style="border-top: 1px dashed black;"/> <p style="margin: 0;">New Version issued</p>	Whole Spec	2016-7- 21	Fei	Athena	

1. Type No./Manufacture's Name

WCN3S-1039SR-C1 / World Components Network Service Ltd.

2. Features:

- High Reliability
- Low Power Requirement
- Easy Assembly

3. Faction: Display Digit Characteristic**4. Soldering Conditions: Soldering Temp. 260 ± 5 °C, Soldering Time. 3~5 sec.**

Soldering Power <30 W.

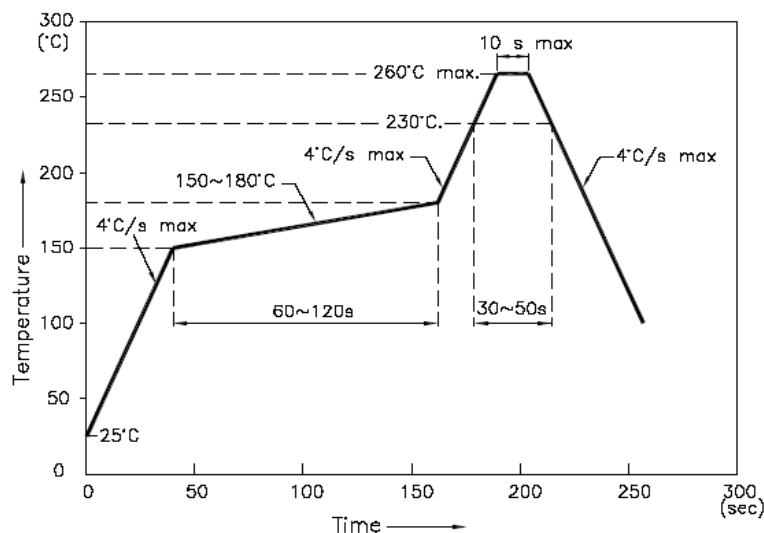
5. Re-flow Temp/Time**NOTES:**

5.1. We recommend the re-flow temperature $245^{\circ}\text{C} (\pm 5^{\circ}\text{C})$. the maximum soldering temperature should be limited to 260°C .

5.2. Don't cause stress to the epoxy resin while it is exposed to high temperature. Number of re-flow process shall be 2 times or less.

6. Description:

- Three Digit LED Display
- Digit Height: 10.0mm (0.39")
- Gray Face and Milky Segment
- Color: Red

Outer Dimension:

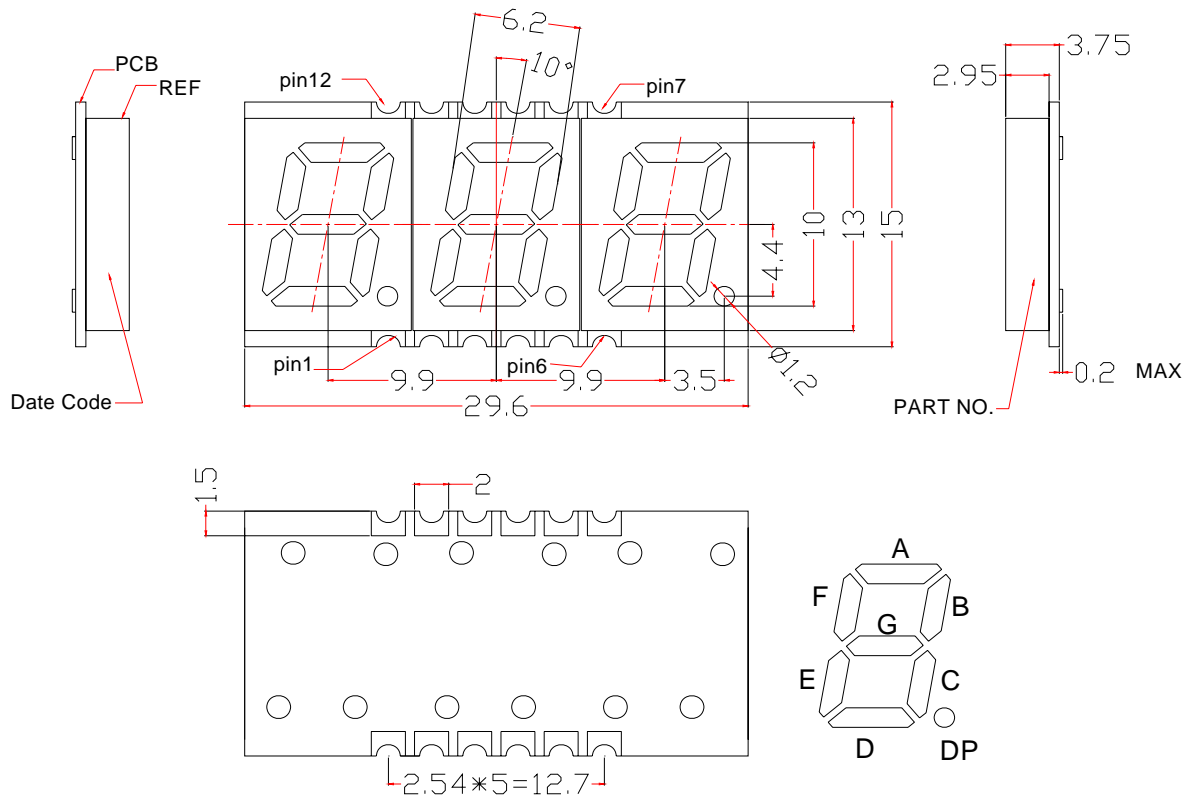

Notes: Unless otherwise stated, the tolerance is $\pm 0.25\text{mm}$.

Circuit Diagram:

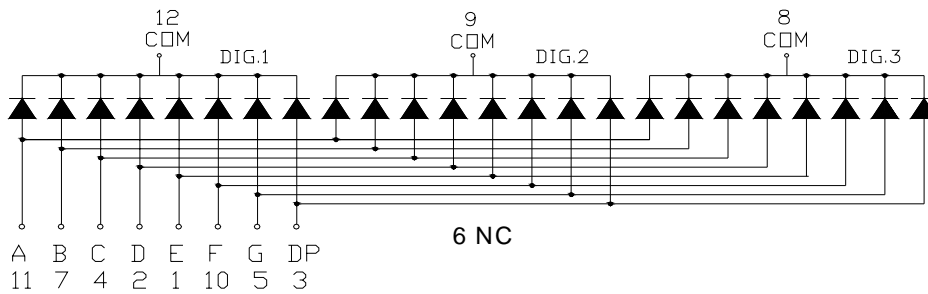

Pin Connection:

PIN NO.	CONNECTION	PIN NO.	CONNECTION
1	Anode E	7	Anode B
2	Anode D	8	Common Cathode Dig.3
3	Anode DP	9	Common Cathode Dig.2
4	Anode C	10	Anode F
5	Anode G	11	Anode A
6	NC	12	Common Cathode Dig.1

World Components Network Service Ltd

■ ABSOLUTE MAXIMUM RATINGS AT TA=25°C

Parameter	Symbol	Condition	Color	Rating	Units
Power Dissipation Per Segment	P_d	—	Red	65	mW
Forward Current Per Segment	I_F	—	Red	25	mA
Peak Forward Current Per Segment	I_{FP}	1/10 Duty 1KHz	Red	100	mA
Reverse Voltage Per Segment	V_R	—	Red	5	V
Operating Temperature Range	T_{opr}	—	—	-40~+105	°C
Storage Temperature Range	T_{stg}	—	—	-40~+105	°C

■ Electrical/Optical Characteristics Rating(Ta=25°C)

Item	Symbol	Test conditions	Location	Rating			Units
				Min.	Typ.	Max.	
Forward Voltage	V_F	$I_F=20mA$	Per Segment	1.80	2.00	2.60	V
Reverse Current	I_R	$V_R=5V$	Per Segment	—	—	100	μA
Luminous Intensity	I_V	$I_F=10mA$	Per Segment	6101	9500	15250	ucd
Wave Length	λ_P	$I_F=20mA$	Per Segment	—	635	—	nm
	λ_D			—	630	—	
Spectral Line Half Width	$\Delta \lambda$	$I_F=20mA$	Per Segment	—	—	20	nm
Luminous Intensity Matching Ratio (Segment To Segment)	I_{v-m}	$I_F=10mA$				1.2:1	

■ Luminous Intensity Sorting: (Luminous intensity tolerance :+/-10%)

Rank	Symbol	Condition	Min	Max	Unit
N	N	$I_F=10mA$	6101	7200	ucd
O	O	$I_F=10mA$	7201	8500	ucd
P	P	$I_F=10mA$	8501	10500	ucd
Q	Q	$I_F=10mA$	10501	12800	ucd
R	R	$I_F=10mA$	12801	15250	ucd

■ **Typical Elector-Optical Characteristics Curve:**

Forward current vs. Forward voltage

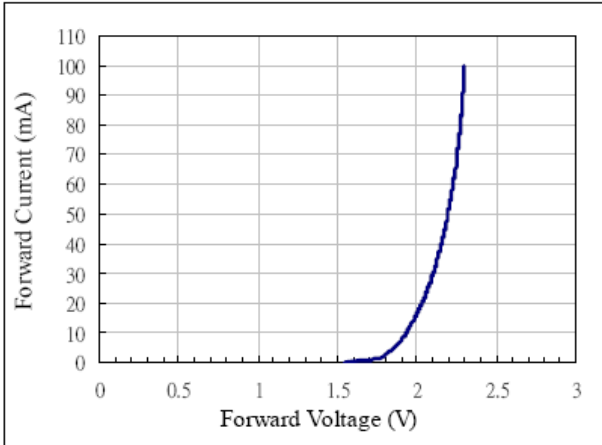

Relative intensity vs. Forward current

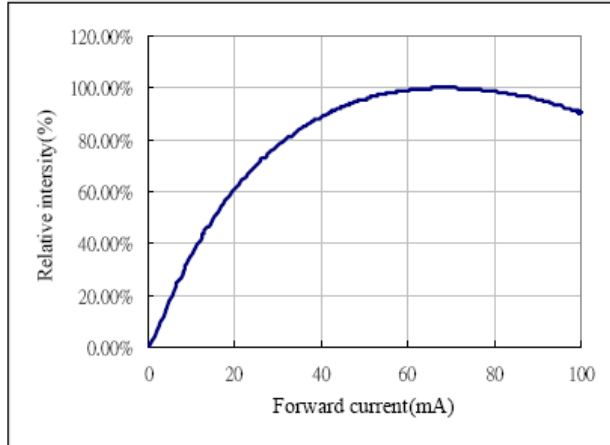

Forward voltage vs. Temperature

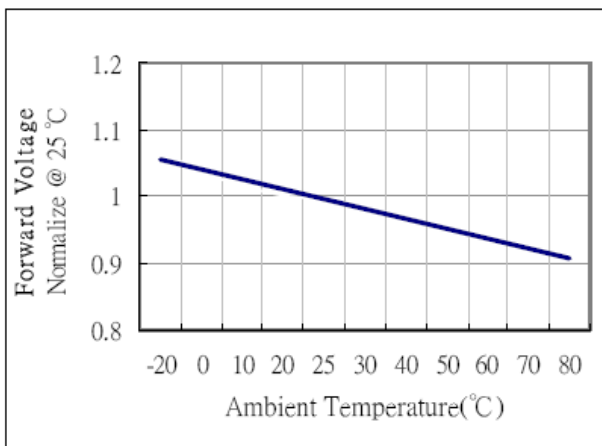

Relative intensity vs. Temperature

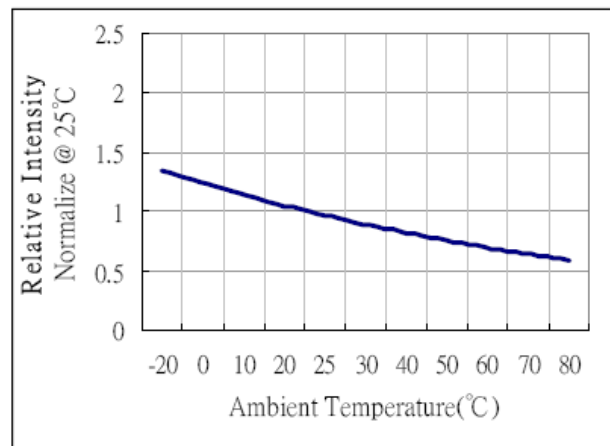

Relative intensity vs. Wavelength

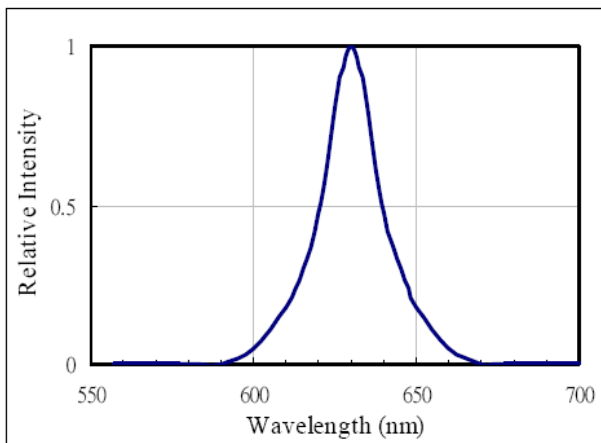

■ Packing Reel Dimensions(mm):

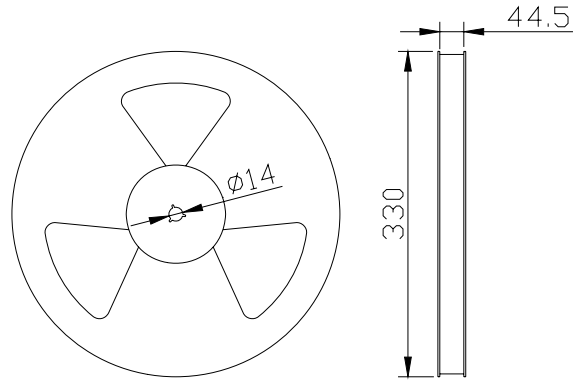

■ Dimensions of Tape (Unit: mm)

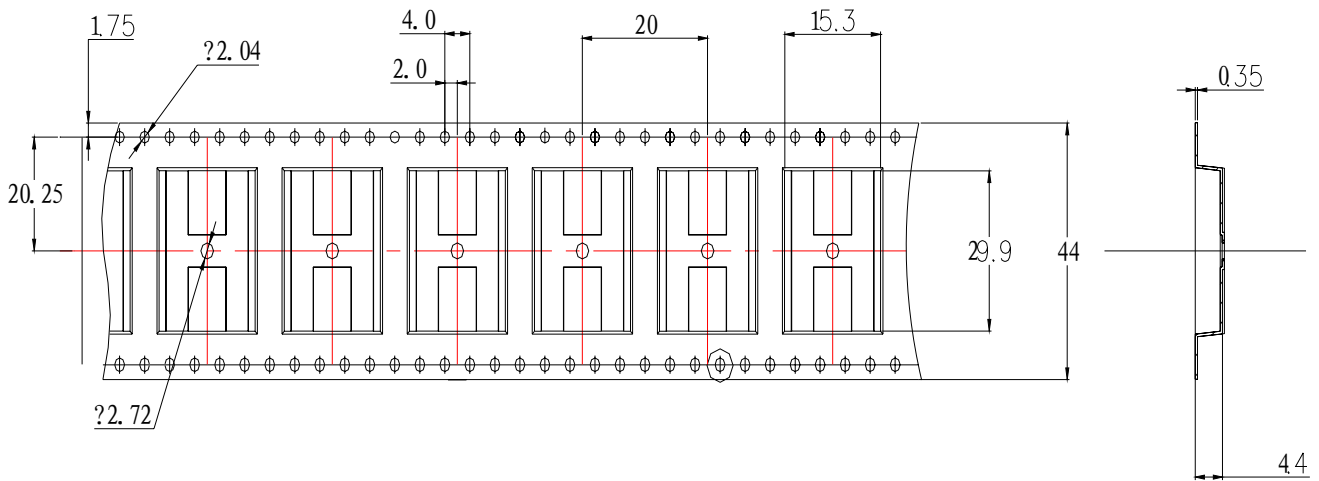

■ One Reel contained 700PCS products:

■ Recommended Soldering Pattern:

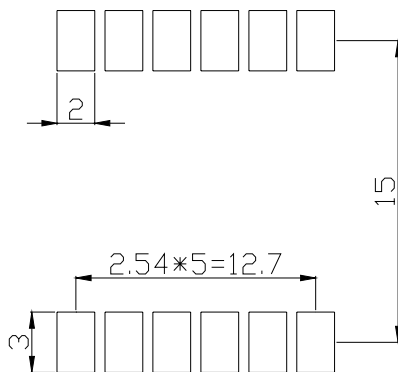

■ **Moisture Proof Packaging:**

All N/D SMD displays are shipped in moisture proof package. The displays should be stored at 30°C or less and 60% RH or less. Once the package opened, moisture absorption begins.

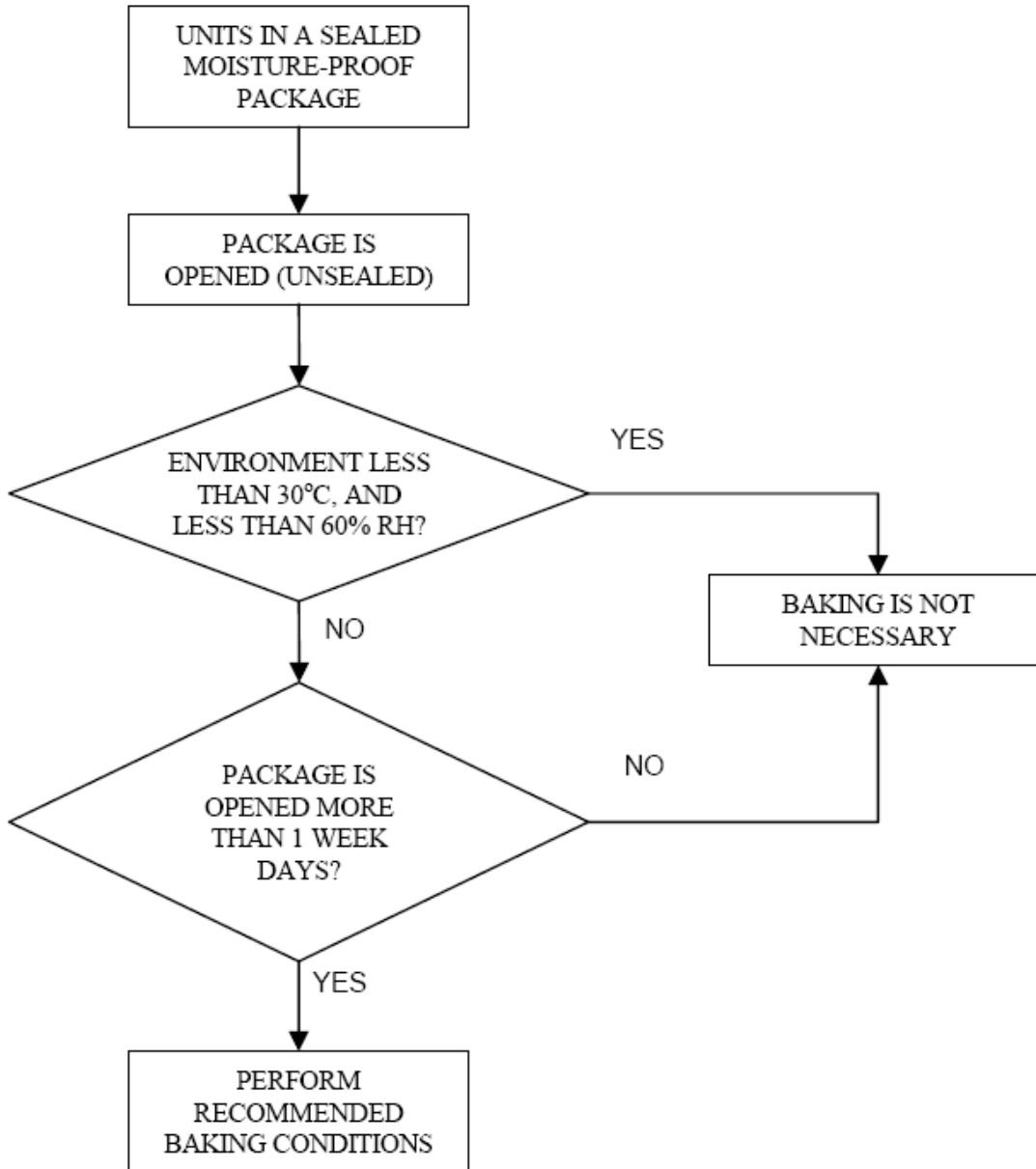

■ **Baking Conditions:**

If the parts not stored in dry conditions, they must be baked before re-flow to prevent damage to the parts.

Package	Temperature	Time
In Reel	60 °C	≥ 48hours
In Bulk	100 °C	≥ 4hours
	125 °C	≥ 2hours

■ **Baking should only be done once.**