

World Components Network Service Ltd

Customer Name:

Date:

2016-2-20

Part No:

WCN3S-1039WW-A1

Product Group
Description:

LED Display

Customer Part No:

Approval Date:

Customer
Confirmation

Approved by

Checked by

Athena
2016-2-20

Prepared By

Fei
2016-2-20



Country of Origin: China

World Components Network Service Ltd

5th Floor,Block A-2,Xuxingda Ind Zone
Shiyan Town,Bao An District , Shenzhen
Tel : (86)755-29000022
Fax : (86)755-29000023



www . wcnopto.net

Table of Contents

NO.	ITEM	PAGE
1	Cover	1
2	Table of Contents	2
3	Revision Record	3
4	Description	4
5	Outer Dimension and Circuit Diagram	5
6	Absolute Maximum Rating and Electrical/Optical Characteristics Rating	6
7	Typical Electrical/ Optical Characteristic Curves and Spectrometer	7
8	Packaging Data	8
9	Moisture Proof Packaging	9



World Components Network Service Ltd

REVISION RECORD

MARKER	Matter for revision	SHEET	DTAE	MAKER	APPOVED SIGN	
	Reason for revision					
A0	P# WCN3S-1039WW-A1 <hr style="border-top: 1px dashed black;"/> New Version issued	Whole Spec	2016-2- 20	Fei	Athena	

1. Type No./Manufacture's Name

WCN3S-1039WW-A1 / World Components Network Service Ltd.

2. Features:

- High Reliability
- Low Power Requirement
- Easy Assembly

3. Faction: Display Digit Characteristic**4. Soldering Conditions: Soldering Temp. 260 ± 5 °C, Soldering Time. 3~5 sec.**

Soldering Power <30 W.

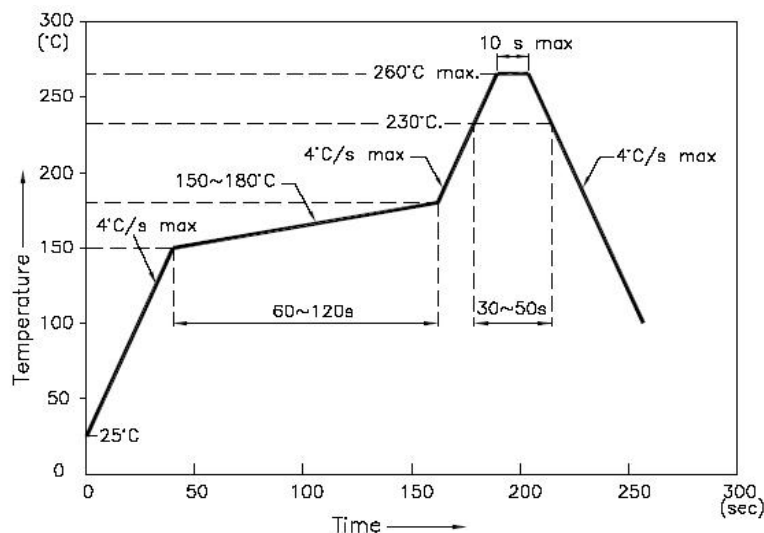
5. Re-flow Temp/Time**NOTES:**

5.1. We recommend the re-flow temperature $245^{\circ}\text{C}(\pm 5^{\circ}\text{C})$. the maximum soldering temperature should be limited to 260°C .

5.2. Don't cause stress to the epoxy resin while it is exposed to high temperature. Number of re-flow process shall be 2 times or less.

6. Description:

- Triad Digit LED Display
- Digit Height: 10.0mm(0.39")
- Gray Face and Milky Segment
- Color: White

Outer Dimension:

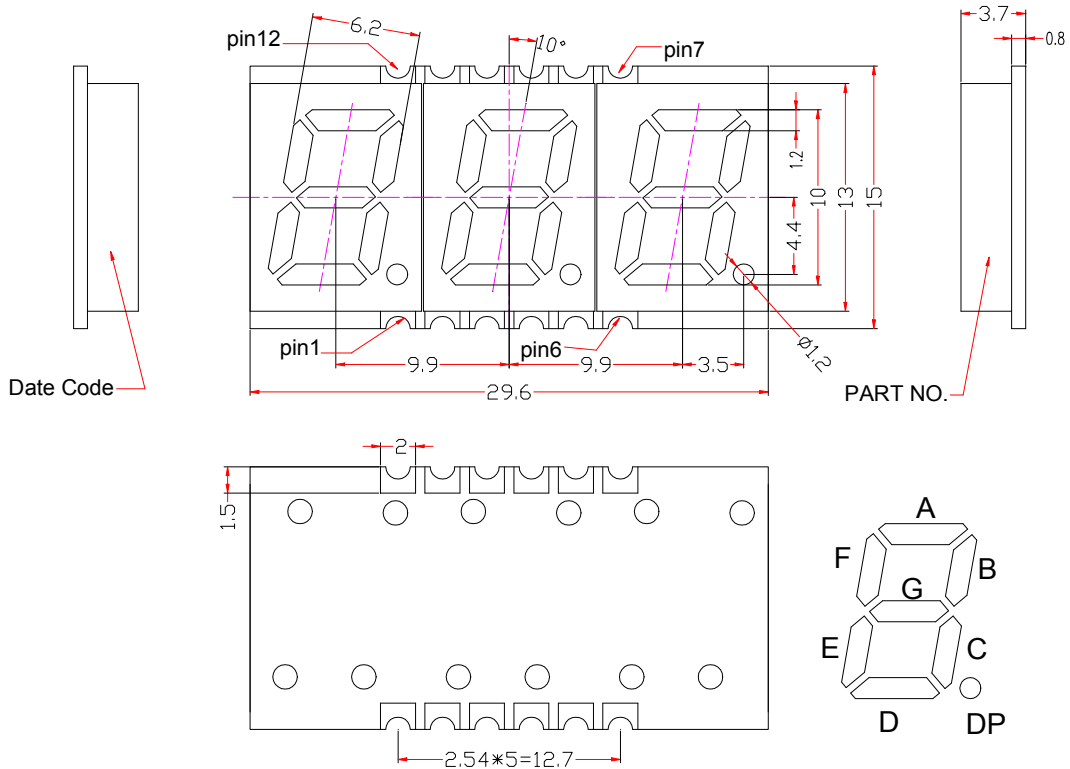

Notes: Unless otherwise stated, the tolerance is $\pm 0.25\text{mm}$.

Circuit Diagram:

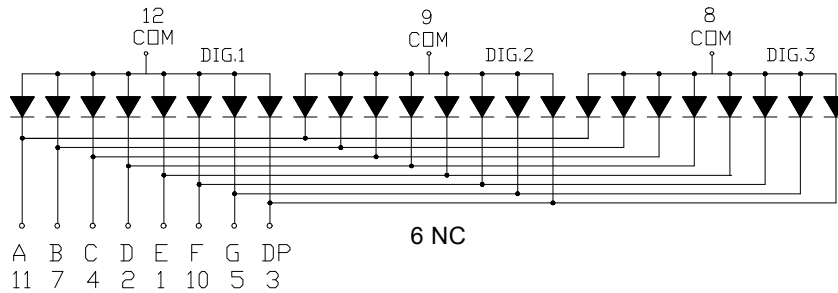

Pin Connection:

PIN NO.	CONNECTION	PIN NO.	CONNECTION
1	Anode E	7	Anode B
2	Anode D	8	Common Cathode Dig.3
3	Anode DP	9	Common Cathode Dig.2
4	Anode C	10	Anode F
5	Anode G	11	Anode A
6	NC	12	Common Cathode Dig.1

World Components Network Service Ltd

■ ABSOLUTE MAXIMUM RATINGS AT TA=25°C

Parameter	Symbol	Condition	Color	Rating	Units
Power Dissipation Per Segment	P _d	—	White	92.5	mW
Forward Current Per Segment	I _F	—	White	25	mA
Peak Forward Current Per Segment	I _{FP}	1/10 Duty 1KHz	White	100	mA
Reverse Voltage Per Segment	V _R	—	White	5	V
Operating Temperature Range	T _{opr}	—	—	-40~+85	°C
Storage Temperature Range	T _{stg}	—	—	-40~+105	°C

■ Electrical/Optical Characteristics Rating(Ta=25°C)

Item	Symbol	Test conditions	Location	Rating			Units
				Min.	Typ.	Max.	
Forward Voltage	V _F	I _F =20mA	Per Chip	2.6	3.0	3.7	V
Reverse Current	I _R	V _R =5V	Per Chip	—	—	100	μA
Luminous Intensity	I _V	I _F =20mA	Per Chip	500	800	1100	mcd
CIE Coordinate	X	I _F =20mA	Per Chip	—	0.2499	—	
	Y			—	0.2403	—	
Luminous Intensity Matching Ratio (Segment To Segment)	I _{v-m}	I _F =10mA				1.2:1	

■ Luminous Intensity Sorting: (Luminous intensity tolerance :+/-10%)

Rank	Symbol	Condition	Min	Max	Unit
G	G	I _F =20mA	500	600	mcd
H	H	I _F =20mA	600	800	mcd
I	I	I _F =20mA	800	1100	mcd

■ **Typical Optical-Electronic Characteristic Curves**

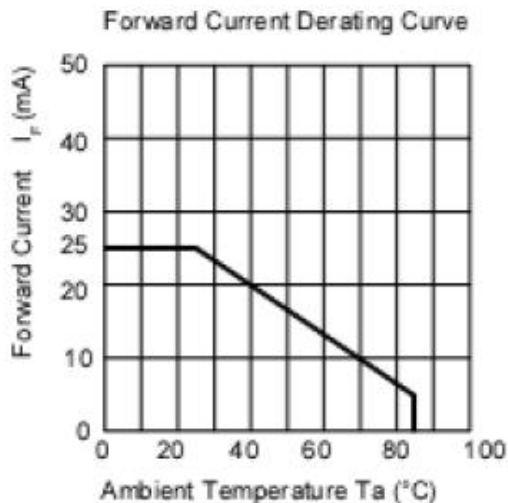
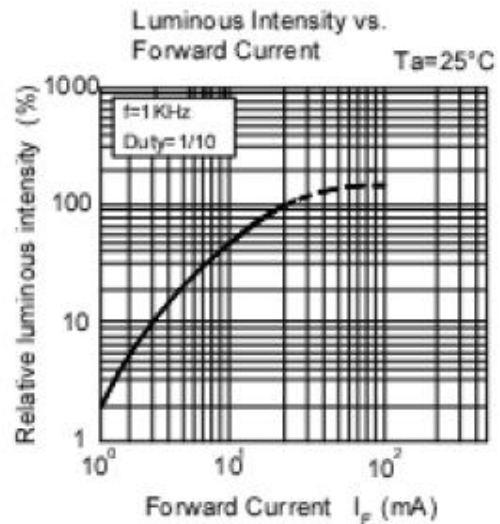
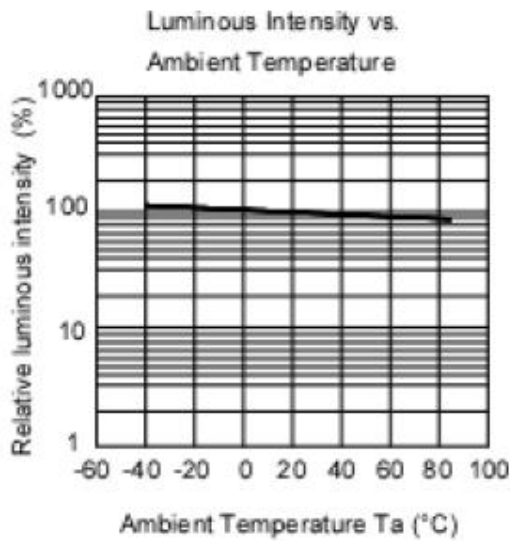
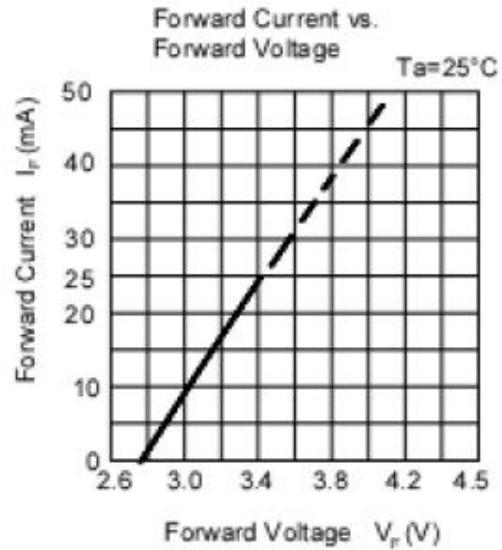
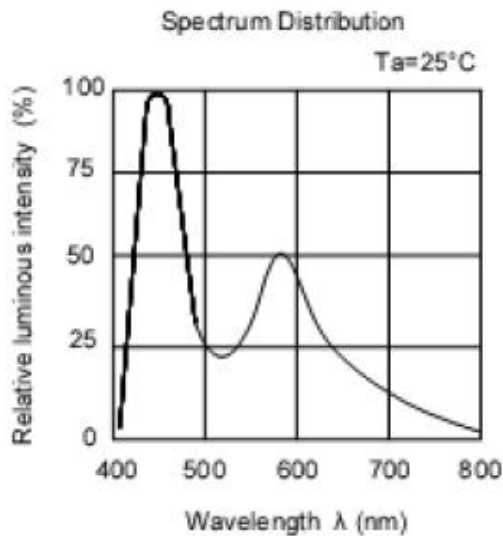

■ **Packing Reel Dimensions(mm):**

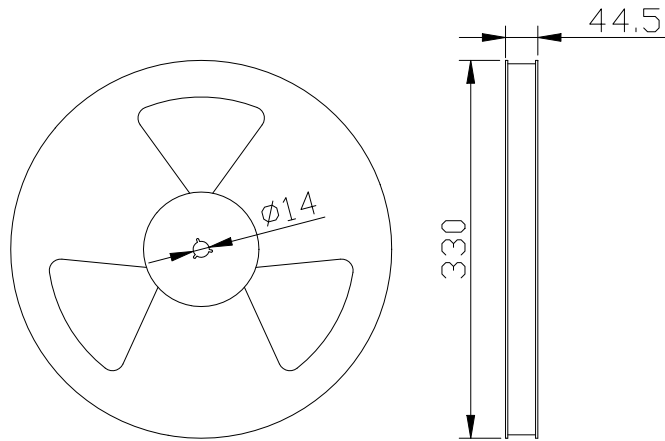

■ **Dimensions of Tape (Unit: mm)**

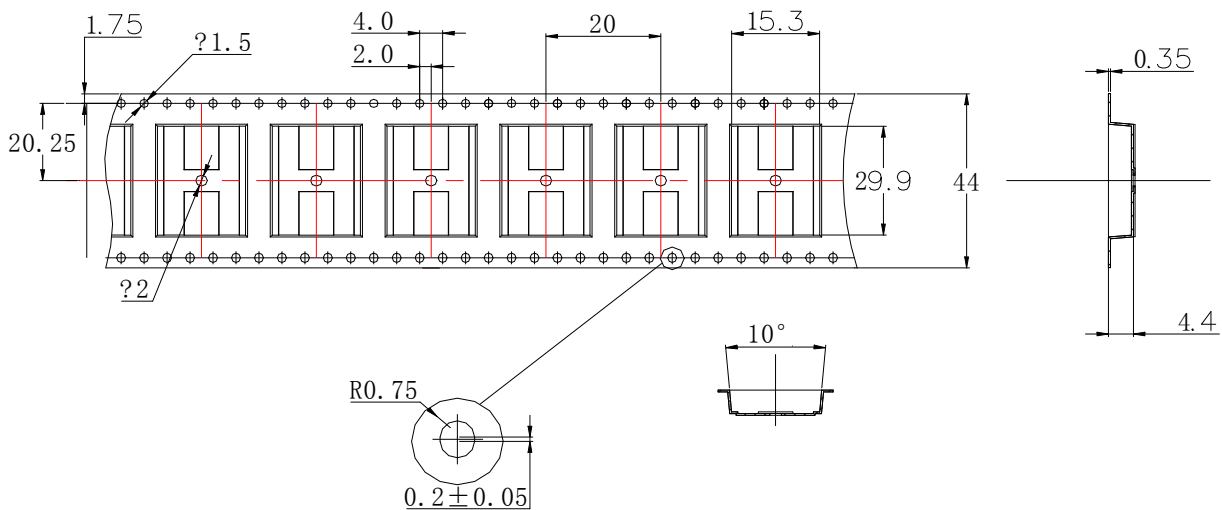

■ **One Reel contained 600 PCS products:**

■ **Recommended Soldering Pattern:**

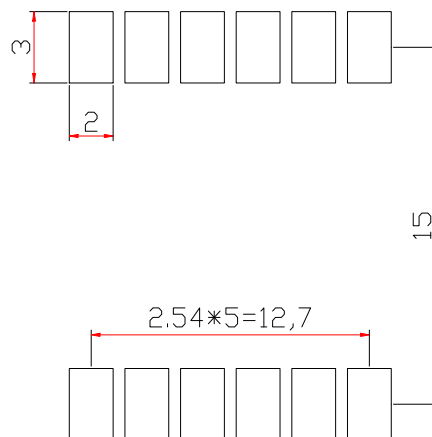

■ **Moisture Proof Packaging:**

All N/D SMD displays are shipped in moisture proof package. The displays should be stored at 30°C or less and 60% RH or less. Once the package opened, moisture absorption begins.

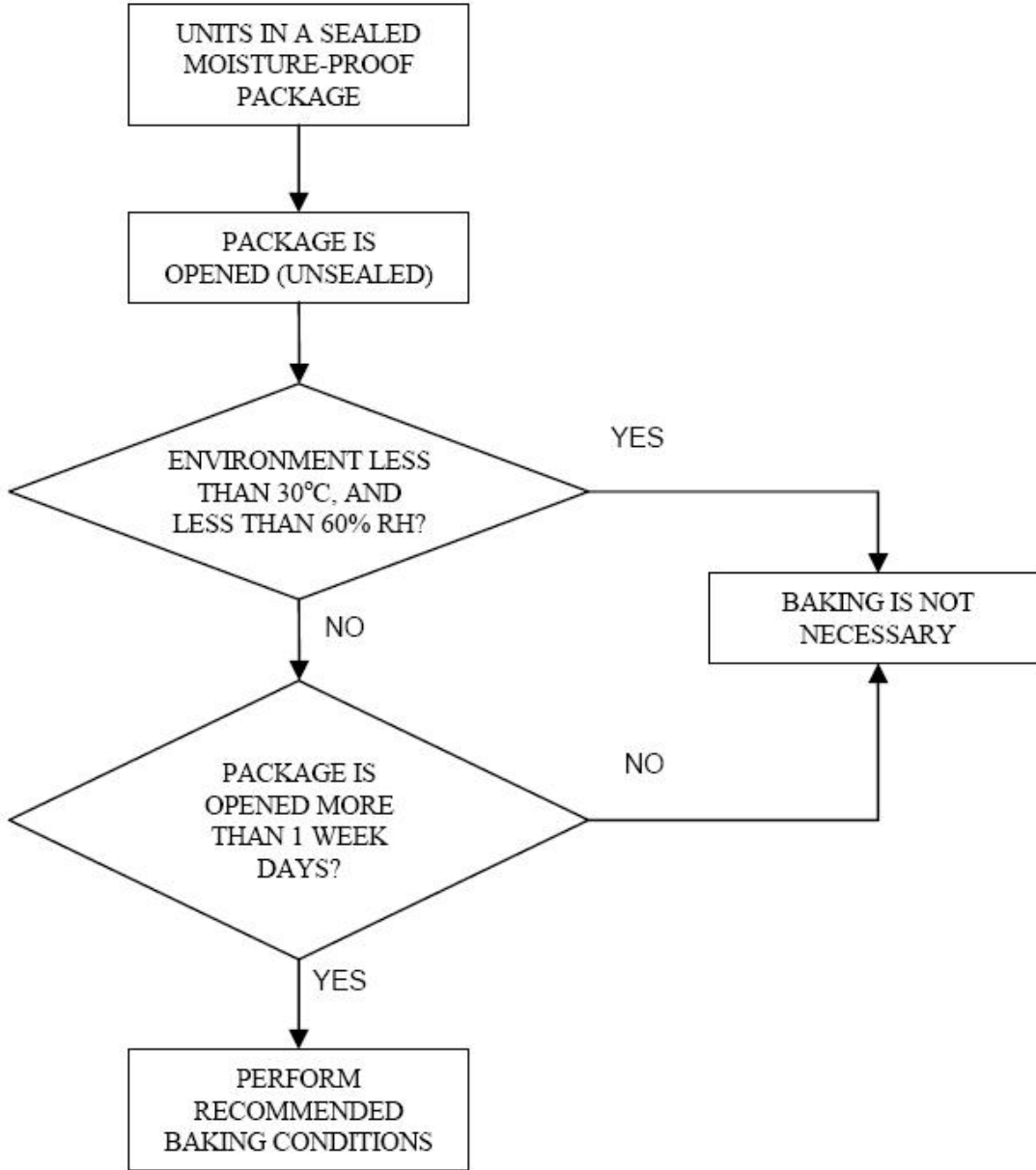

■ **Baking Conditions:**

If the parts not stored in dry conditions, they must be baked before re-flow to prevent damage to the parts.

Package	Temperature	Time
In Reel	60 °C	≥ 48hours
In Bulk	100 °C	≥ 4hours
	125 °C	≥ 2hours

■ **Baking should only be done once.**