



WCN Opto Group Co., Limited

Customer Name:

Date:

2024-10-6

Part No:

WCN3S-1040B7-C1

Product Group
Description:

LED Display

Customer Part No:

Approval Date:

Customer
Confirmation

Approved by

William
2024-10-6

Checked by

Athena
2024-10-6

Prepared By

Liu
2024-10-6

Country of Origin: China

WCN Opto Group Co., Limited

Buildings 1 and 2, No. 13, Songnan Road,
Sanhe Village, Tonghu Town,
Zhongkai High Tech Zone, Huizhou, Guangdong

Tel : (86)755-29520866

Mail:williamzhang@wcnopto.net



www . wcnopto.net

Table of Contents

NO.	ITEM	PAGE
1	Cover	1
2	Table of Contents	2
3	Revision Record	3
4	Description	4
5	Outer Dimension and Circuit Diagram	5
6	Absolute Maximum Rating and Electrical/Optical Characteristics Rating	6
7	Typical Electrical/ Optical Characteristic Curves and Spectrometer	7
8	Packaging Data	8
9	Moisture Proof Packaging	9

1. Type No./Manufacture's Name**WCN3S-1040B7-C1 / WCN Opto Group Co., Limited.****2. Features:**

- **High Reliability**
- **Low Power Requirement**
- **Easy Assembly**

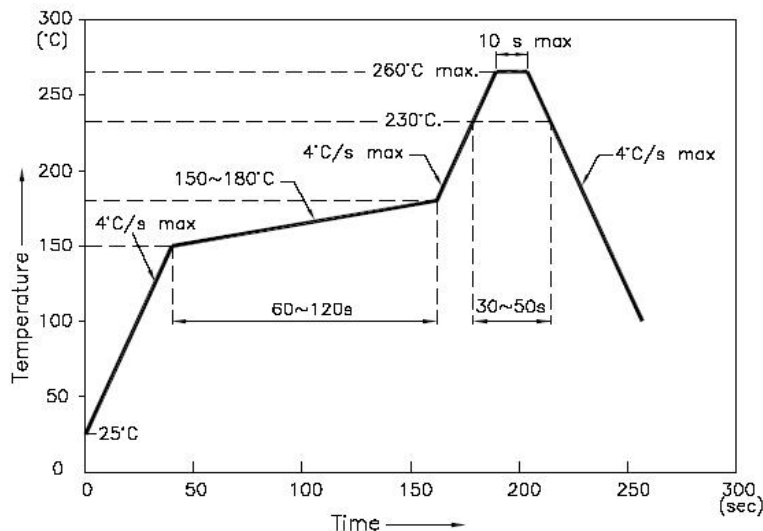
3. Faction: Display Digit Characteristic**4. Soldering Conditions: Soldering Temp. 260 ± 5 °C, Soldering Time. 3~5 sec.****Soldering Power <30 W.****5. Re-flow Temp/Time****NOTES:**

5.1. We recommend the re-flow temperature $245^{\circ}\text{C}(\pm 5^{\circ}\text{C})$.the maximum soldering temperature should be limited to 260°C .

5.2. Don't cause stress to the epoxy resin while it is exposed to high temperature. Number of re-flow process shall be 2 times or less.

6. Description:

- **Three Digit LED Display**
- **Digit Height:10.16mm(0.40")**
- **Gray Face and Milky Segment**
- **Color: Blue**

Outer Dimension:

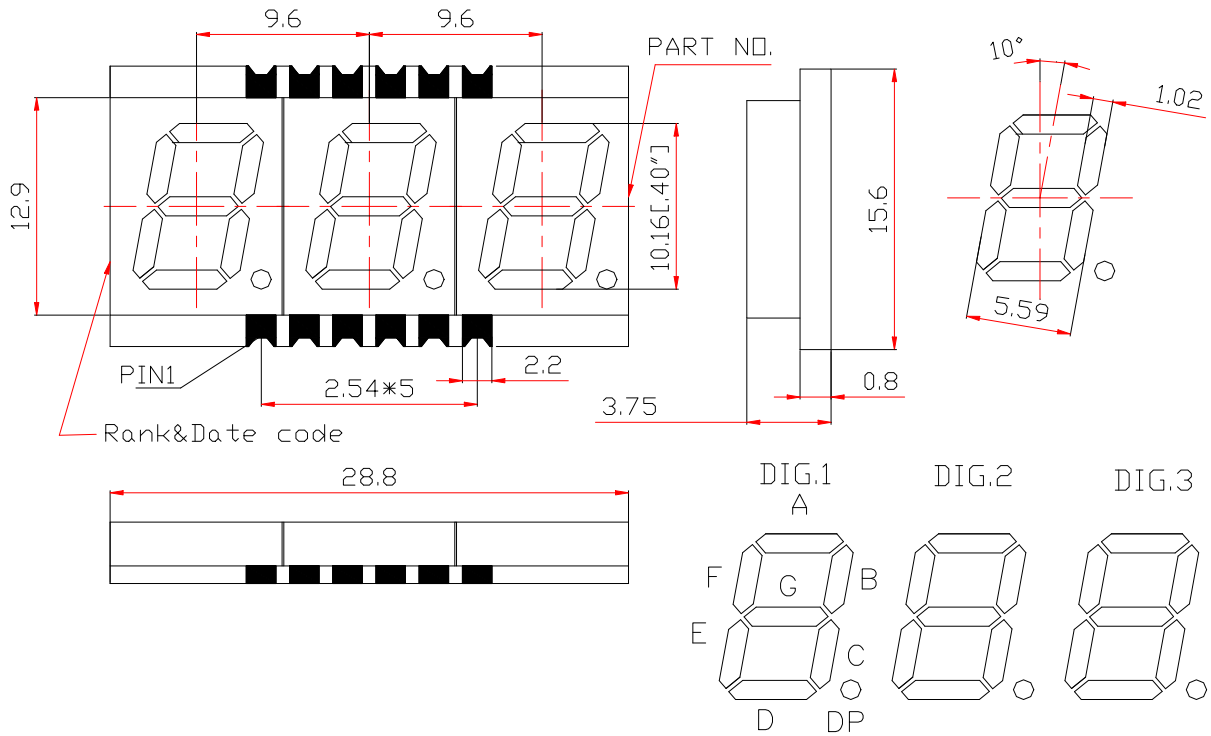

Notes: Unless otherwise stated, the tolerance is $\pm 0.25\text{mm}$.

Circuit Diagram:

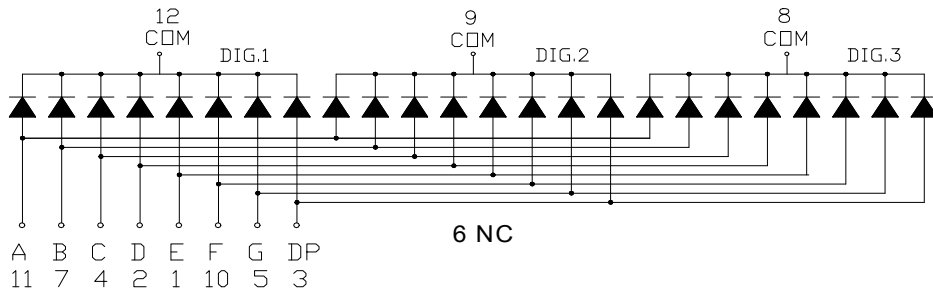

Pin Connection:

PIN NO.	CONNECTION	PIN NO.	CONNECTION
1	Anode E	7	Anode B
2	Anode D	8	Common Cathode Dig.3
3	Anode DP	9	Common Cathode Dig.2
4	Anode C	10	Anode F
5	Anode G	11	Anode A
6	NC	12	Common Cathode Dig.1

WCN Opto Group Co., Limited

ABSOLUTE MAXIMUM RATINGS AT TA=25°C

Parameter	Symbol	Condition	Color	Rating	Units
Power Dissipation Per Segment	P_d	—	Blue	85	mW
Forward Current Per Segment	I_F	—	Blue	25	mA
Peak Forward Current Per Segment	I_{FP}	1/10 Duty 1KHz	Blue	100	mA
Reverse Voltage Per Segment	V_R	—	Blue	5	V
Operating Temperature Range	T_{opr}	—	—	-40~+105	°C
Storage Temperature Range	T_{stg}	—	—	-40~+105	°C

Electrical/Optical Characteristics Rating(Ta=25°C)

Item	Symbol	Test conditions	Location	Rating			Units
				Min.	Typ.	Max.	
Forward Voltage	V_F	$I_F=20mA$	Per Segment	2.6	3.0	3.4	V
Reverse Current	I_R	$V_R=5V$	Per Segment	—	—	100	μA
Luminous Intensity	I_V	$I_F=10mA$	Per Segment	12.8	19.5	31.0	mcd
Wave Length	λ_P	$I_F=20mA$	Per Segment	—	460	—	nm
	λ_D			—	465	—	
Spectral Line Half Width	$\Delta \lambda$	$I_F=20mA$	Per Segment	—	—	20	nm
Luminous Intensity Matching Ratio (Segment To Segment)	I_{v-m}	$I_F=10mA$				1.2:1	

Luminous Intensity Sorting: (Luminous intensity tolerance :+/-10%)

Rank	Symbol	Condition	Min	Max	Unit
R	R	$I_F=10mA$	12.801	15.250	mcd
S	S	$I_F=10mA$	15.251	18.000	mcd
T	T	$I_F=10mA$	18.001	21.500	mcd
U	U	$I_F=10mA$	21.501	26.000	mcd
V	V	$I_F=10mA$	26.001	31.000	mcd

■ Typical Elector-Optical Characteristics Curve:

Fig1. Forward Current vs. Forward Voltage:

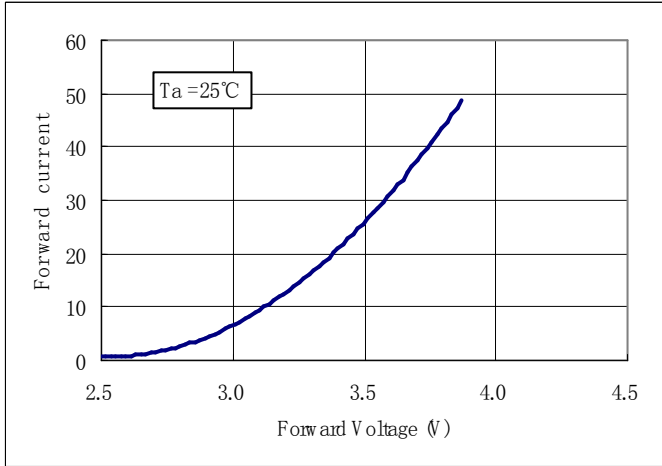

Fig2. Forward Current vs. Relative Intensity:

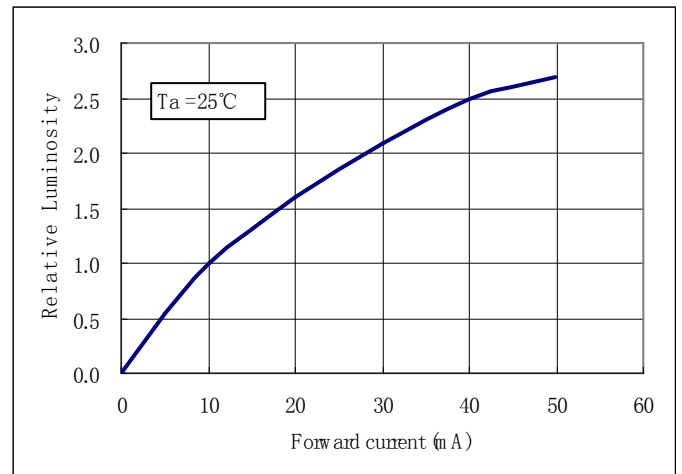

Fig3. Forward Current vs. Relative wavelength:

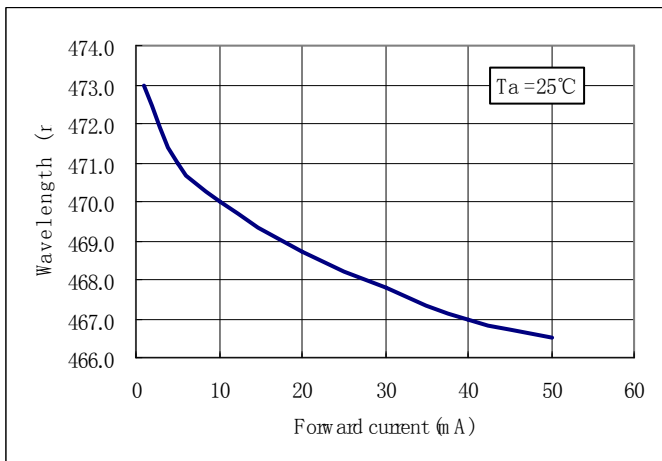
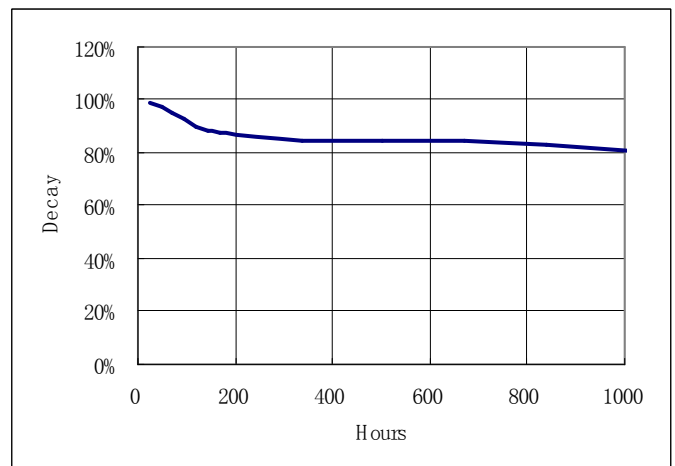
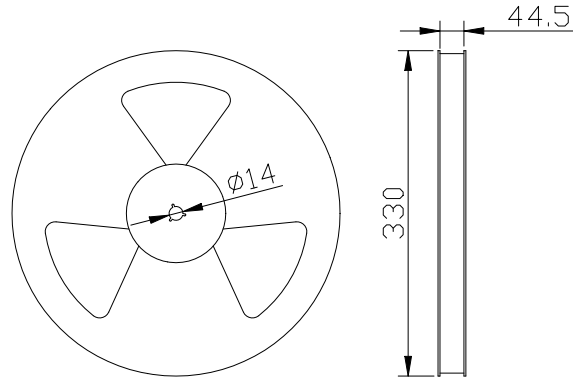

Fig4. Life Test at 20mA R.T. 1000hrs:



WCN Opto Group Co., Limited

■ Packing Reel Dimensions(mm):



■ Dimensions of Tape (Unit: mm)

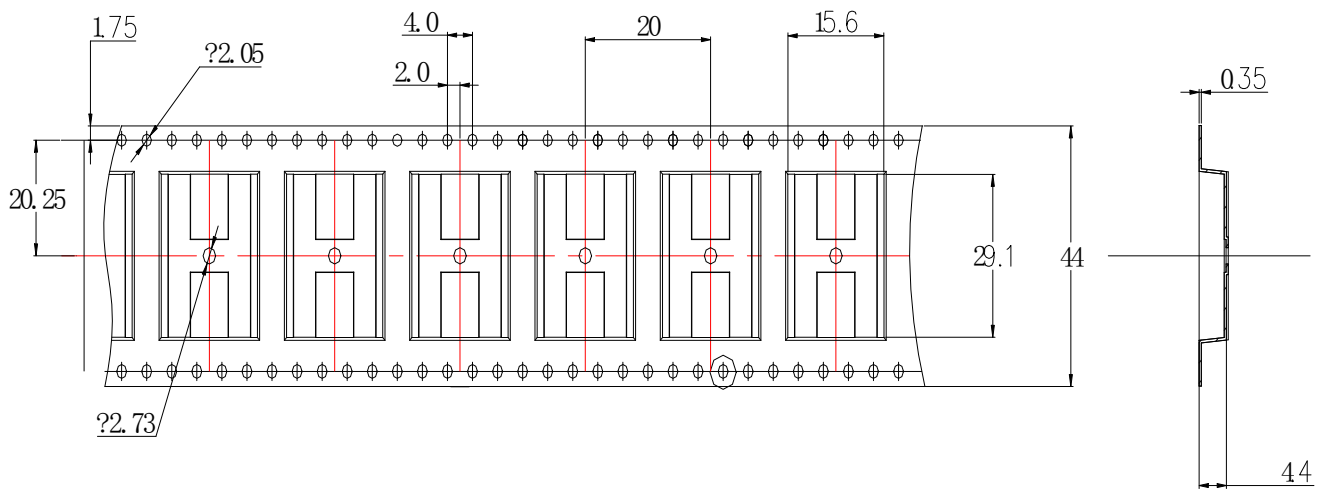

■ One Reel contained 780 PCS products:

■ Recommended Soldering Pattern:

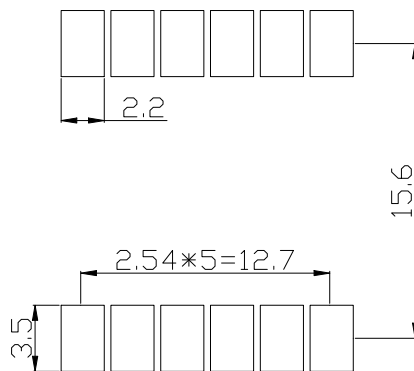

Moisture Proof Packaging:

All N/D SMD displays are shipped in moisture proof package. The displays should be stored at 30°C or less and 60% RH or less. Once the package opened, moisture absorption begins.

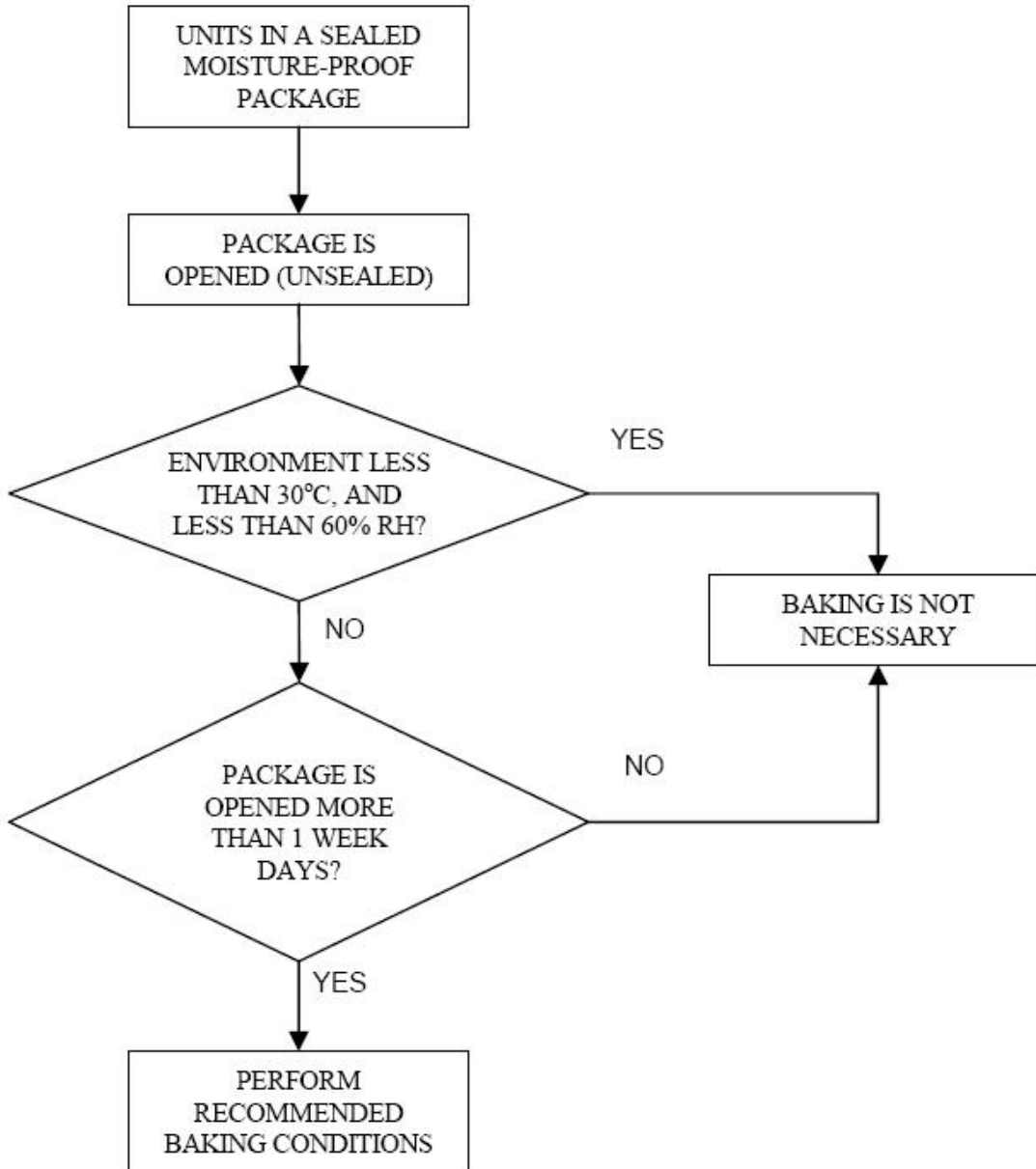

Baking Conditions:

If the parts not stored in dry conditions, they must be baked before re-flow to prevent damage to the parts.

Package	Temperature	Time
In Reel	60 °C	≥ 48hours
In Bulk	100 °C	≥ 4hours
	125 °C	≥ 2hours

■ Baking should only be done once.