

**WCN Opto Group Co., Limited****Customer Name:****Date:**

2023-8-1

**Part No:**

WCN3S-1056SR-C5

**Product Group  
Description:**

LED Display

**Customer Part No:****Approval Date:****Customer  
Confirmation****Approved by**William  
2023-8-1**Checked by**Athena  
2023-8-1**Prepared By**Zhang  
2023-8-1**Country of Origin: China****World Components Network Service Ltd****5th Floor,Block A-2,Xuxingda Ind Zone  
Shiyan Town,Bao An District , Shenzhen  
Tel : (86)755-29000022  
Fax : (86)755-29000023****RoHS****www . wcnopto.net**

**Table of Contents**

<b>NO.</b>	<b>ITEM</b>	<b>PAGE</b>
1	Cover	1
2	Table of Contents	2
3	Revision Record	3
4	Description	4
5	Outer Dimension and Circuit Diagram	5
6	Absolute Maximum Rating and Electrical/Optical Characteristics Rating	6
7	Typical Electrical/ Optical Characteristic Curves and Spectrometer	7
8	Packaging Data	8
9	Moisture Proof Packaging	9



# WCN Opto Group Co., Limited

## REVISION RECORD

MARKER	Matter for revision	SHEET	DTAE	MAKER	APPOVED SIGN	
	Reason for revision					
A0	P# WCN3S-1056SR-C5	Whole Spec	2023-8-1	Zhang	Athena	William
	New Version issued					

**1. Type No./Manufacture's Name**

WCN3S-1056SR-C5 / WCN Opto Group Co., Limited.

**2. Features:**

- High Reliability
- Low Power Requirement
- Easy Assembly

**3. Faction: Display Digit Characteristic****4. Soldering Conditions: Soldering Temp.  $260 \pm 5$  °C, Soldering Time. 3~5 sec.**

Soldering Power <30 W.

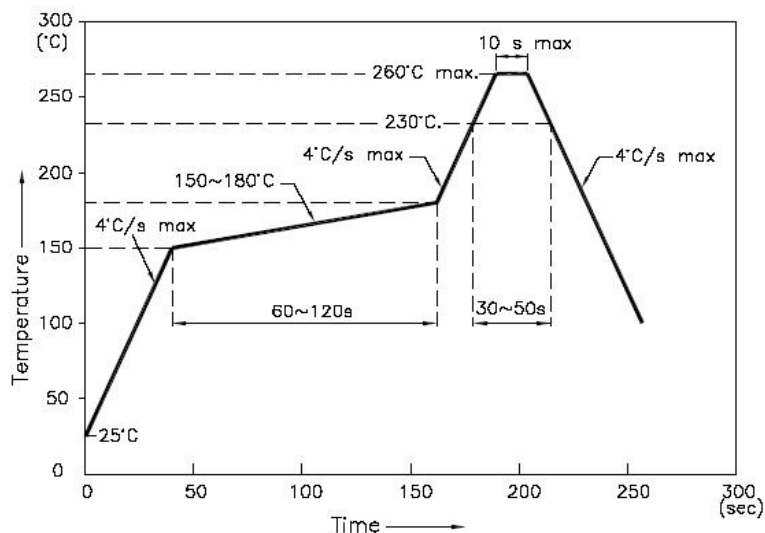
**5. Re-flow Temp/Time****NOTES:**

5.1. We recommend the re-flow temperature  $245^{\circ}\text{C}(\pm 5^{\circ}\text{C})$ . the maximum soldering temperature should be limited to  $260^{\circ}\text{C}$ .

5.2. Don't cause stress to the epoxy resin while it is exposed to high temperature. Number of re-flow process shall be 2 times or less.

**6. Description:**

- Three Digit LED Display
- Digit Height: 14.2mm(0.56" )
- Gray Face and Milky Segment
- Color: Red

## Outer Dimension:

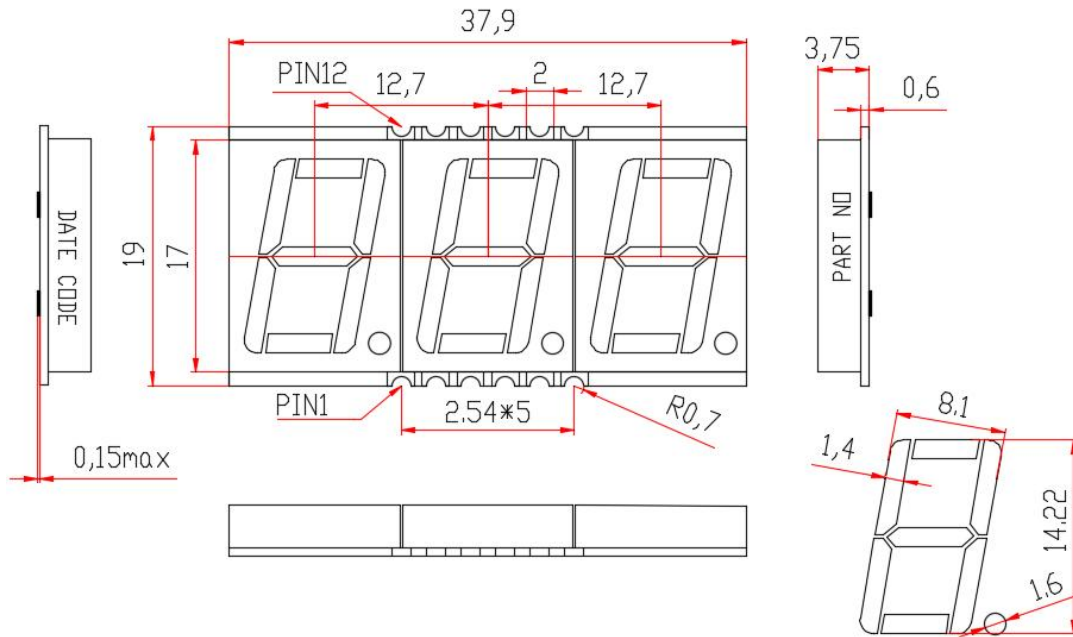

Notes: Unless otherwise stated, the tolerance is  $\pm 0.25\text{mm}$ .

## Circuit Diagram:

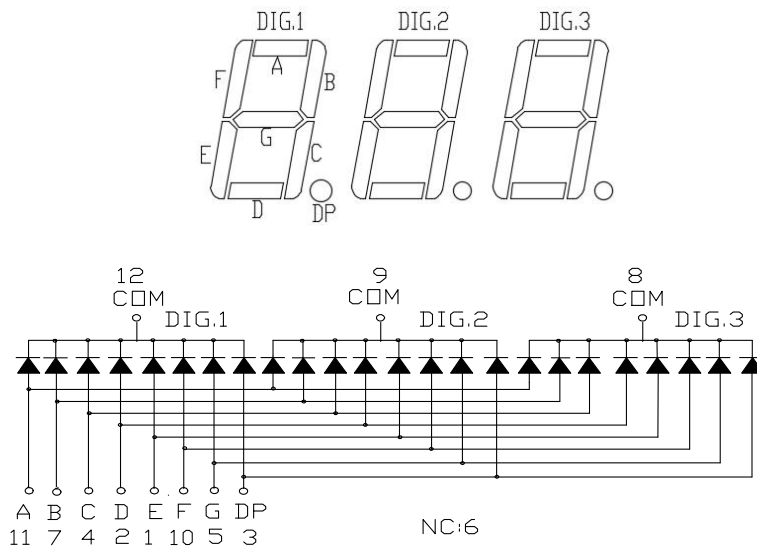

## Pin Connection:

PIN NO.	CONNECTION	PIN NO.	CONNECTION
1	Anode E	7	Anode B
2	Anode D	8	Common Cathode Dig.3
3	Anode DP	9	Common Cathode Dig.2
4	Anode C	10	Anode F
5	Anode G	11	Anode A
6	NC	12	Common Cathode Dig.1

## ABSOLUTE MAXIMUM RATINGS AT TA=25°C

Parameter	Symbol	Condition	Color	Rating	Units
Power Dissipation Per Segment	P <sub>d</sub>	—	Red	65	mW
Forward Current Per Segment	I <sub>F</sub>	—	Red	25	mA
Peak Forward Current Per Segment	I <sub>FP</sub>	1/10 Duty 1KHz	Red	100	mA
Reverse Voltage Per Segment	V <sub>R</sub>	—	Red	5	V
Operating Temperature Range	T <sub>opr</sub>	—	—	-40~+105	°C
Storage Temperature Range	T <sub>stg</sub>	—	—	-40~+105	°C

## Electrical/Optical Characteristics Rating(Ta=25°C)

Item	Symbol	Test conditions	Location	Rating			Units
				Min.	Typ.	Max.	
Forward Voltage	V <sub>F</sub>	I <sub>F</sub> =20mA	Per Chip	1.8	2.0	2.6	V
Reverse Current	I <sub>R</sub>	V <sub>R</sub> =5V	Per Chip	—	—	100	μA
Luminous Intensity	I <sub>V</sub>	I <sub>F</sub> =10mA	Per Chip	4001	6500	10500	ucd
Wave Length	λ <sub>P</sub>	I <sub>F</sub> =20mA	Per Chip	—	635	—	nm
	λ <sub>D</sub>			—	630	—	
Spectral Line Half Width	Δλ	I <sub>F</sub> =20mA	Per Chip	—	—	20	nm

## Luminous Intensity Sorting: (Luminous intensity tolerance :+/-10%)

Rank	Symbol	Condition	Min	Max	Unit
L	L	I <sub>F</sub> =10mA	4001	5000	ucd
M	M	I <sub>F</sub> =10mA	5001	6100	ucd
N	N	I <sub>F</sub> =10mA	6101	7200	ucd
O	O	I <sub>F</sub> =10mA	7201	8500	ucd
P	P	I <sub>F</sub> =10mA	8501	10500	ucd

## ■ Typical Optical-Electronic Characteristic Curves

Forward current vs. Forward voltage

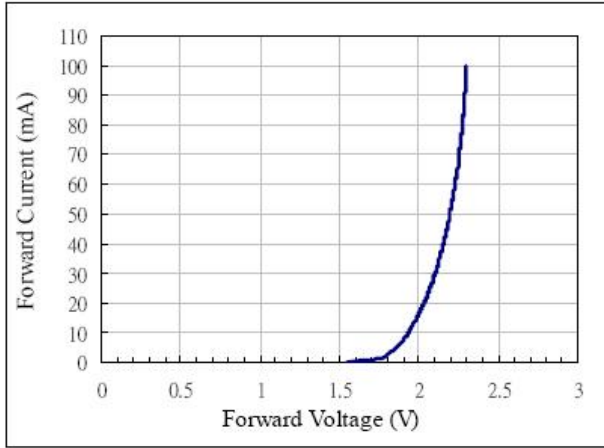

Relative intensity vs. Forward current

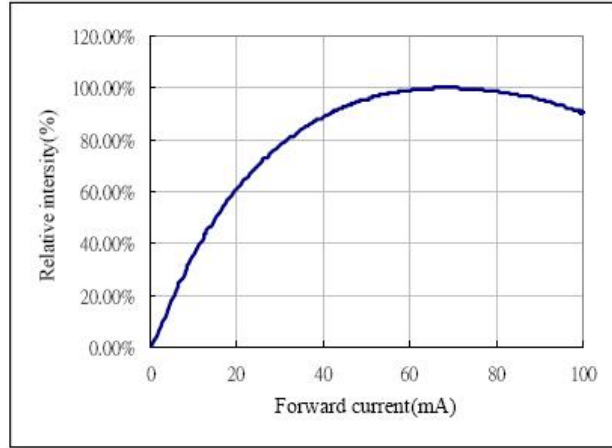

Forward voltage vs. Temperature

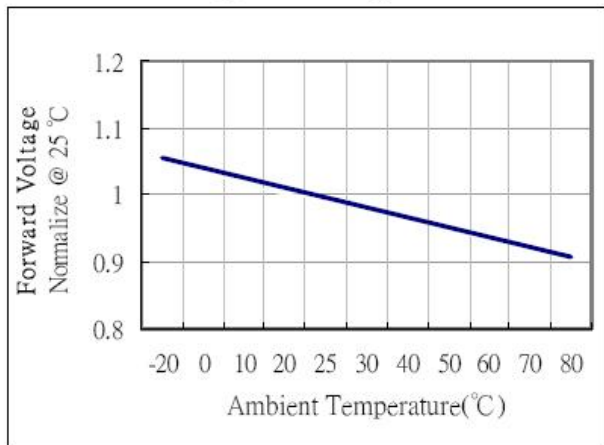

Relative intensity vs. Temperature

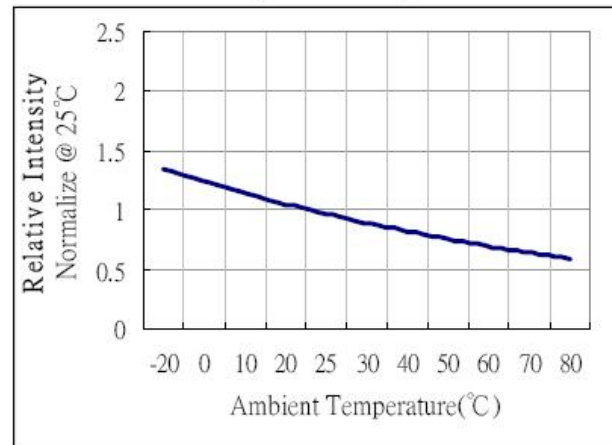

Relative intensity vs. Wavelength

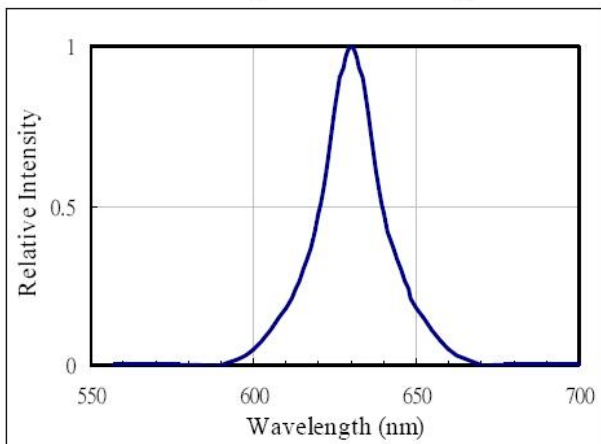

■ Packing Reel Dimensions(mm):

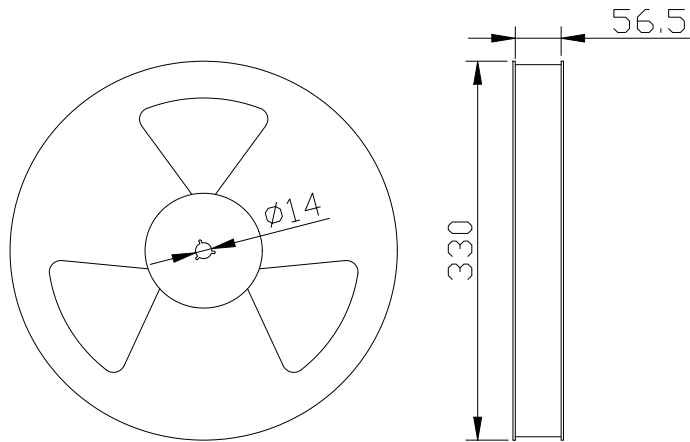

■ One Reel contained 650 PCS products:

■ Recommended Soldering Pattern:

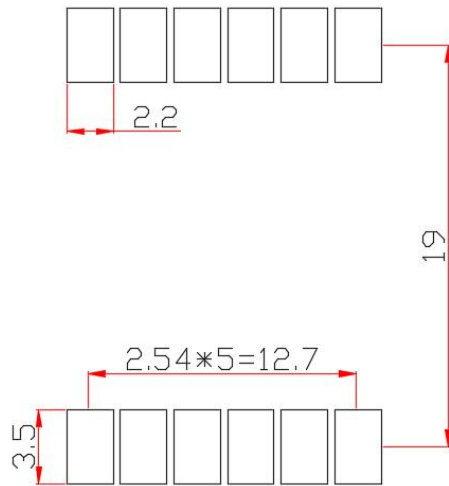



## Moisture Proof Packaging:

All N/D SMD displays are shipped in moisture proof package. The displays should be stored at 30°C or less and 60% RH or less. Once the package opened, moisture absorption begins.

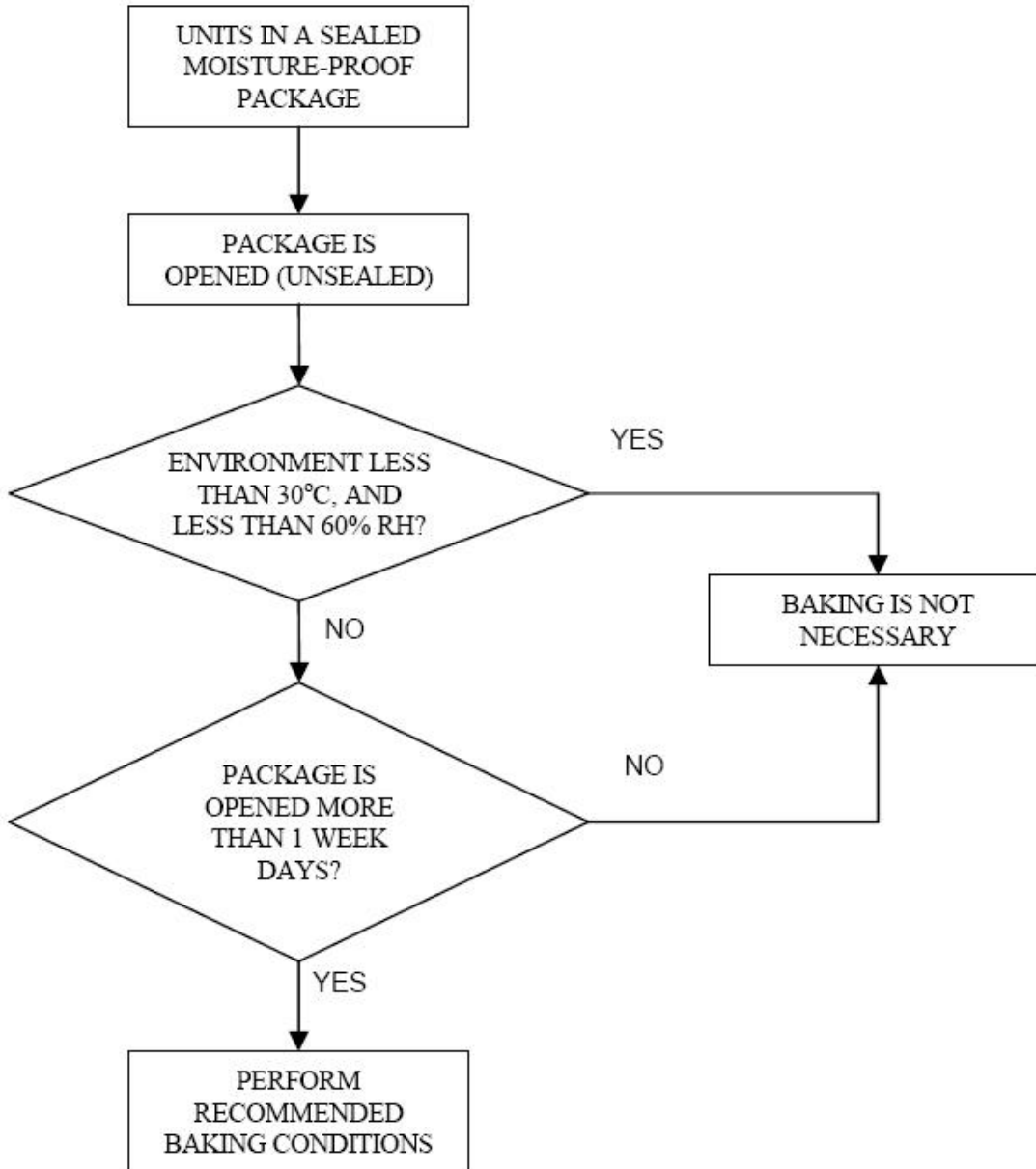

## Baking Conditions:

If the parts not stored in dry conditions, they must be baked before re-flow to prevent damage to the parts.

Package	Temperature	Time
In Reel	60 °C	≥ 48hours
In Bulk	100 °C	≥ 4hours
	125 °C	≥ 2hours

## Baking should only be done once.